

**DESIGN AND CONSTRUCTION
REQUIREMENTS
FOR SANITARY SEWERS**

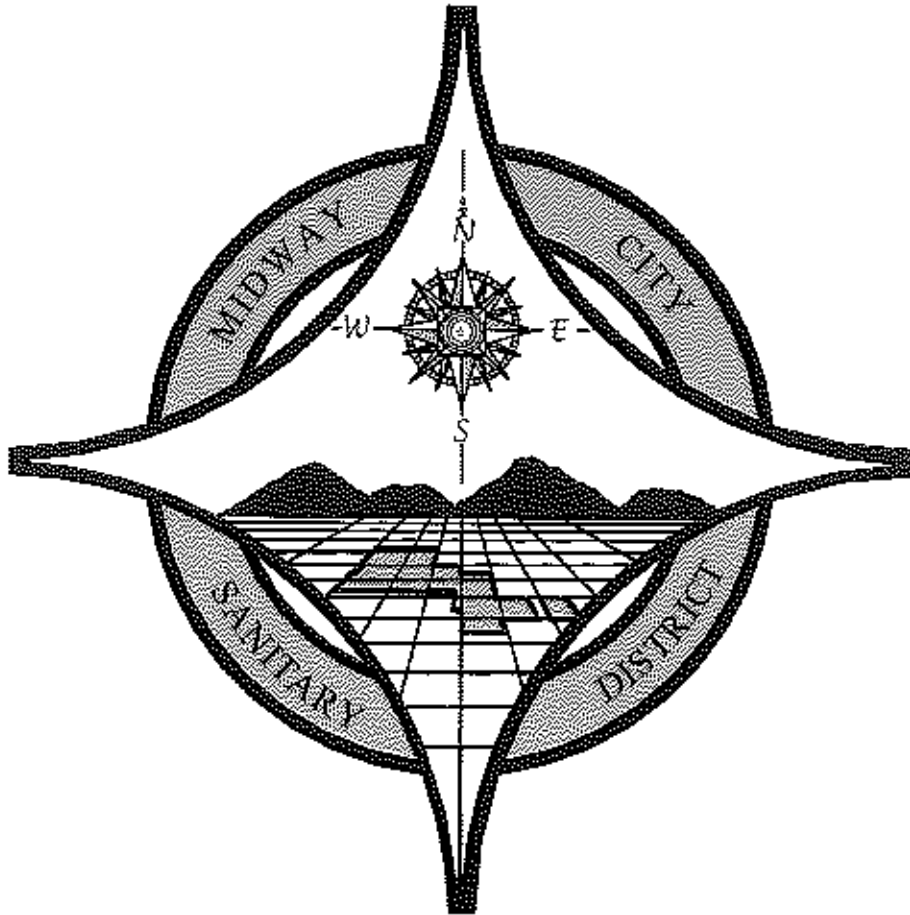

**MIDWAY CITY SANITARY DISTRICT
WESTMINSTER, CALIFORNIA
BOARD APPROVED 11/2/2010**

TABLE OF CONTENTS

	<u>PAGE</u>
<u>SECTION 1 – GENERAL</u>	1
1-1 – Definitions	1
1-2 – Plan Check and Approval of Plans	1
1-3 – Payment of Fees	1
1-4 – "As-Built" Drawings	1
<u>SECTION 2 – DESIGN REQUIREMENTS</u>	2
2-1 – Design Criteria	2
2-2 – Preparation of Drawings	3
2-3 – Sewer Construction on Private Property	3
<u>SECTION 3 – INSPECTION OF WORK</u>	4
<u>SECTION 4 – SEWER CONSTRUCTION</u>	6
4-1 – General	6
4-2 – Connection to Existing Facilities	6
4-3 – Sewer and Water Separation	6
4-4 – Special Provisions	6
<u>SECTION 6 – STANDARD DRAWINGS</u>	8
S-010 Pipe Installation and Pavement Replacement	8
S-011 Sewer – Storm Drain Crossing	9
S-012 2 Way Clean Out on Private Property	10
S-013 Raised Sewer Manhole in Alley Gutter	11
S-015 Sewer Clean Out Cover and Frame Installation	12
S-018 Concrete Encasement Type A, B, & C	13
S-019 Pipeline Separation Requirements	14
S-020 Pipe Support Beam Across Trenches	16
S-021 Pipe Support Wall Across Trenches	17
S-022 Sewer House Lateral at Utility Intersection	18
S-023 Anchor Block Detail	19
S-030A Steel Pipe Casing	20
S-040 Field Closure for V.C.P.	21
S-044 Bell Ring Insert with PVC Plate Liner	22
S-045A Un-Lined Manhole for Sewers	23
S-050A PVC-Lined Manhole for Sewers	24
S-051 Drop Manhole Connection to Standard Manhole	27
S-053A Standard Manhole Frame and Cover	28
S-054A Bolted Manhole Frame and Cover	29
S-055A Manhole Adjustment to Grade	30
S-056 PVC Liner and Gas Flap Installation at Laterals	31
S-057 Gas Flap Installation for NON-PVC Lined or Unlined Manholes	32
S-065 Liner-PVC	33
S-070 Saddle Connection	34
S-071 Cut in WYE Connection	36
S-072 House Lateral, Typical	36
S-073 Clean Out Detail in Roadway	37
Grease Interceptor Tank with Sample Box	38

SECTION 1 – GENERAL

1-1 DEFINITIONS

DISTRICT - Midway City Sanitary District

DISTRICT ENGINEER – Engineer or Authorized Representative for the District

STANDARD SPECIFICATIONS FOR PUBLIC WORKS CONSTRUCTION

All references to the standard Specifications refer to the latest edition as revised or amended at the date of construction.

ASTM – The American Society for Testing and Materials, latest revision.

APPROVED EQUAL – A material or product that is equivalent to or exceeds, in the opinion of the District Engineer, in all respects, that which is specified.

1-2 PLAN CHECK AND APPROVAL OF PLANS

Construction drawings of the proposed sewer construction within the District boundary shall be submitted and approved by the District Engineer, attested to by the Engineer's signature on the drawings. This approval shall apply only to general design concepts and does not guarantee the absence of errors or omissions.

1-3 PAYMENT OF FEES

Prior to approval of plans and connections to District sewers, the developer shall pay all fees as required under current District policy. Fees will be determined by the District Engineer at time of plan check.

1-4 "AS-BUILT" DRAWINGS

In the case dedicated sewer main is constructed, the Design Engineer shall "As-Built" the original drawings to the satisfaction of the District Engineer and provide the District with a set of duplicate mylars.

SECTION 2 – DESIGN REQUIREMENTS

2-1 Design Criteria

(a) Minimum size – The minimum size for sewer mains shall be 8-inches and for laterals 4-inches.

(b) Sewer Slop – Minimum pipeline slopes shall be:

<u>Pipe Size (Mains)</u>	<u>Grade</u>
8 inch	0.40%
10 inch	0.28%
12 inch	0.22%
15 inch	0.16%
18 inch	0.12%
4 inch (laterals)	2.0%

(c) Pipe Capacity – Pipelines shall be designed to carry estimated peak flow as follows:

18-inch or smaller – flowing ½ full

21-inch or larger – flowing ¾ full

(d) Manholes – Manhole construction is required at the following locations:

- (1) At changes of slop
- (2) At changes of direction
- (3) At changes of pipe size
- (4) At junction of laterals larger than 6-inches
- (5) At intervals not exceeding 350 feet
- (6) At termination of sewer mains
- (7) At special locations as designated by the District Engineer

Elevation drop through manholes shall be 0.10 foot minimum.

SECTION 2 – DESIGN REQUIREMENTS (Continued)

(e) Pipe Material – Polyvinyl Chloride (PVC) pipe is approved for all sewer line construction. Vitrified Clay Pipe (VCP) pipe may be specified only with prior approval from the District Engineer. Ductile Iron Pipe (DIP), or Class 200 Polyvinyl Chloride (PVC) – C900, shall be used for sewer construction within the vicinity of water mains as in Standard Drawing S-019.

(f) Curved Sewer – Curved sewer may be specified only with prior approval from the District Engineer.

2-2 Preparation of Drawings

All sewer plans shall be prepared as follows:

Sheet Size: 24 by 36 inches

Scales: Horizontal – one inch equals 40 feet. Vertical – one inch equals 4 feet for sewer slopes less than 10 percent. One inch equals 8 feet for slopes greater than 10 percent.

Sewer Plans: Sewer plan shall show both existing and proposed construction and shall include standard notes and a signature block for the District Engineer. (Sewer profile will be required when public sewer main is proposed.)

Sewer Mains and Lateral Location: Sewer Mains and Lateral location shall be shown on the plans and located by stationing. Stationing shall conform to the existing stationing.

2-3 Sewer Construction on Private Property

Sewer mains constructed on private property that are to be maintained by the Midway Way City Sanitary District shall be shown within a 20 foot easement to be dedicated to the District. Only under instances approved by the Board of Directors and the District Engineer will sewer within easements be accepted by the District.

SECTION 3 -- INSPECTION OF WORK

The Midway City Sanitary District (MCSD) shall provide an inspector for the inspection of all sewer improvements constructed within the public right-of-way or MCSD easements. All work shall be left open and uncovered until the installation is observed by the District Inspector. The contractor shall not proceed with any subsequent phase of work until the previous phase has been inspected by the District.

The term inspection referred to herein shall mean observation by the District Inspector or other District representative and does not constitute or imply any guarantees.

Inspection shall be made at the following intervals of work:

- (a) Trench excavation and bedding
- (b) Placing of pipe, fittings and structures
- (c) Placing and compacting of the pipe bedding
- (d) Backfill of balance of trench to grade; in public right-of-way, Performed by local governing agency; within easements, entire backfill to be under inspection by the District Inspector
- (e) Balling and cleaning, air testing and mirroring, after receipt of Compaction certification, but prior to paving
- (f) Repairs made after initial inspection
- (g) After manholes are raised to grade
- (h) Saddle or manhole connections to existing sewers

The District shall at all times have access to work during construction and shall be furnished with every reasonable facility for ascertaining full knowledge of the progress, workmanship and character of materials used and employed in the work.

No pipe, fitting or other materials shall be installed until inspected by the District or its representative. All installations which are to be backfilled shall be inspected prior to backfilling and the contractor shall give due notice to the District Engineer in advance of backfilling so that proper inspection may be provided.

SECTION 3 – INSPECTION OF WORK (Continued)

The inspection of the work shall not relieve the contractor of any of his obligations to complete the work as prescribed by these specifications, defective work shall be made good, and unsuitable materials may be rejected notwithstanding the fact that such defective work and unsuitable materials have been previously overlooked by the District and accepted.

The District shall have the authority to suspend the inspection of the work wholly or in part for such time as it may deem necessary due to the failure on the part of the contractor to comply with these specifications as determined by the District Engineer. Any work performed without inspection of the District shall be considered unacceptable.

SECTION 4 – SEWER CONSTRUCTION

4-1 General

All work shall conform to the standard Specifications for Public Works Construction except as modified herein, the work Area Traffic Control Watch Manuel Handbook, and the standard Plans and Specifications of the Midway City Sanitary District.

The contractor shall be responsible for obtaining all necessary permits and shall Comply with all safety ordinances, regulations, orders, and shall be solely Responsible for the safety conditions of the work.

4-2 Connection to Existing Facilities

Modification to existing manhole shall be done by core drilling unless otherwise approved by the District Engineer. New channels in existing manholes shall be finished smooth and shaped in the direction of flow. Any annular space around the pipe at the manhole base shall be filled with plastic cement (1:3 field mix).

4-3 Sewer and Water Separation

All new sewer construction shall maintain a minimum distance of 10 feet horizontally and 1 foot vertically below water mains. Any construction above the water main or in violation of the basic separation requirements shall be done per Standard Drawing S-019.

4-4 Special Provisions

The following additions are made to the Standard Specifications for Public Works Construction:

Adjustment of Manholes Frame and Cover Sets to Grade

Prior to asphalt concrete paving, manhole frame and covers shall be left 6 inches below finish grade. After street surfacing is completed, frames and covers shall be raised to grade per Standard Drawing S-055A. Whenever manholes are constructed in unpaved areas, the manhole covers shall be set 18 inches above finished grade.

SECTION 4 – SEWER CONSTRUCTION (continued)

Bedding

Pipe bedding shall meet the approval of the District Engineer and local governing agencies.

Field Jointing of Clay Pipe

Only Type "G" joints are approved for vitrified clay pipe (VCP) with the exception that Type "D" joints may be used for laterals and sewer repair work.

Backfill and Densification

All trench backfill and bedding shall be compacted to 90 percent minimum Relative compaction unless otherwise required by the local governing agency.

Trench Resurfacing

Trench resurfacing shall meet the requirements of the local governing agency.

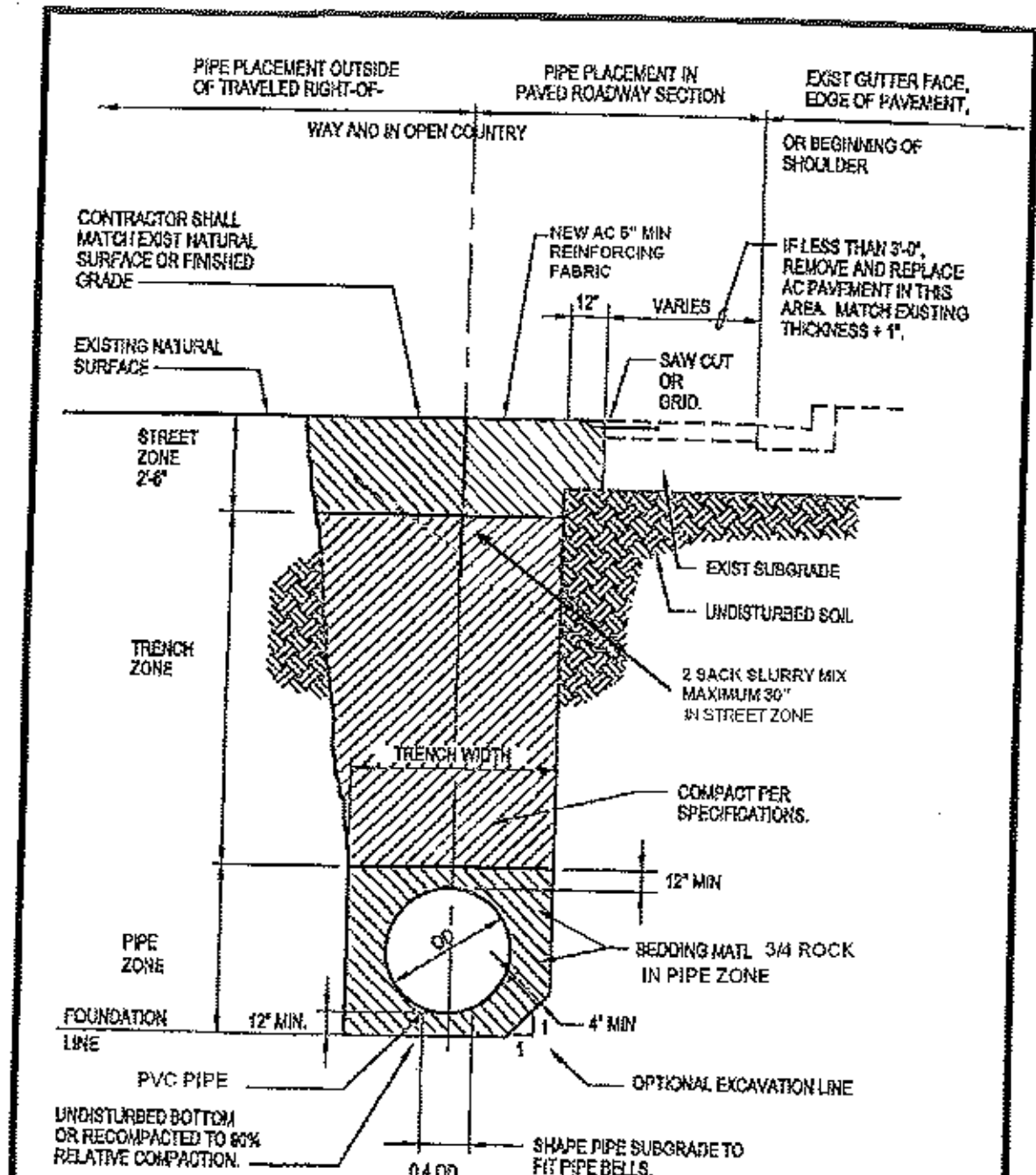

NOTE:

TRENCH WIDTH, BEDDING AND BACKFILL MATERIALS, COMPACTION AND PAVING PER SPECIFICATIONS.

No.	APPROVED	DATE

MIDWAY CITY SANITARY DISTRICT
 WRESTON, CA
Handwritten signature 11/2/2018

PIPE INSTALLATION
 AND
 PAVEMENT REPLACEMENT

NO SCALE
 STANDARD DWG.
 S-010

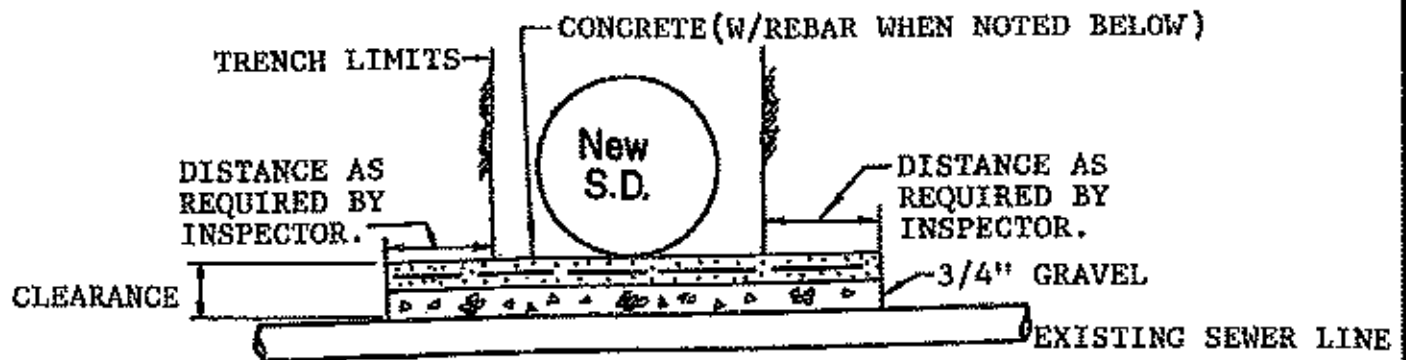

IF CLEARANCE IS 8" TO 18", USE 4" CONCRETE SLAB OVER 4" OF 3/4" GRAVEL.
 IF CLEARANCE IS LESS THAN 8", USE CONCRETE SLAB W/ REBAR OVER 3/4" GRAVEL
 AS REQUIRED BY INSPECTOR.

CASE I

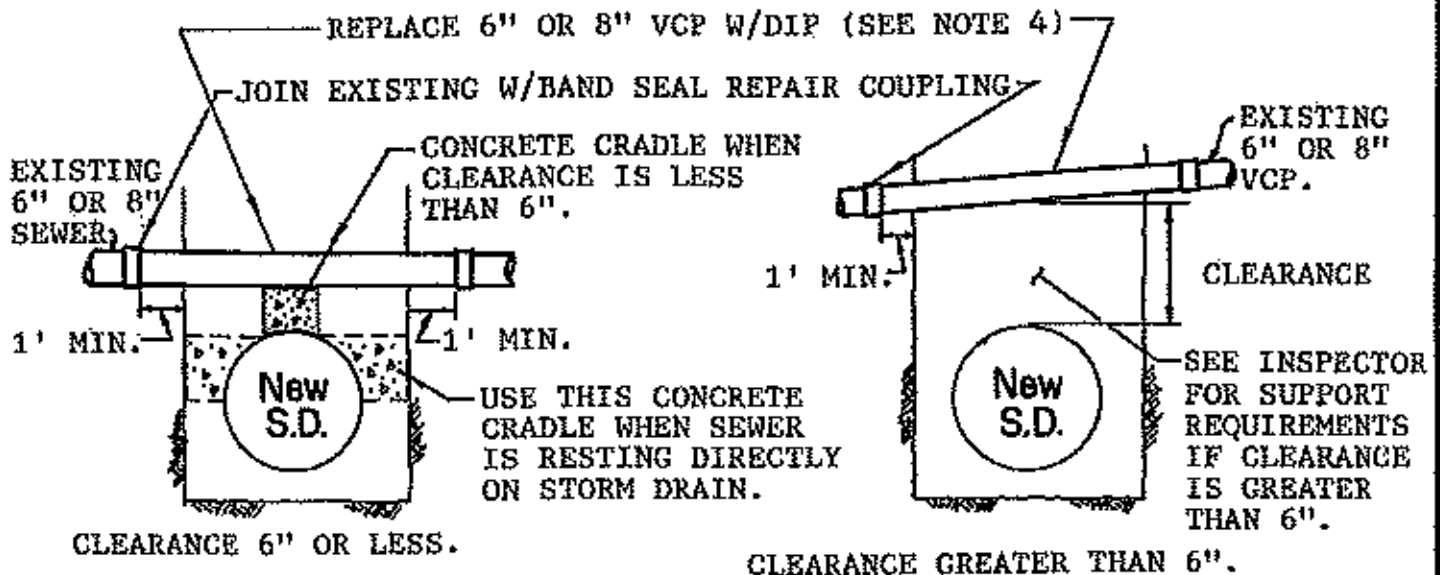

CLEARANCE 6" OR LESS.

CLEARANCE GREATER THAN 6".

CASE II

CASE III

Notes:

1. For use in conjunction with storm drain construction in the vicinity of sewer lines to prevent damage to sewer during backfill operation.
2. This standard does not meet the State Department of Health requirements for sewer and water crossing.
3. Case III may be used with the construction of new water main with prior approval of District Engineer.
4. 10" VCP or larger to be protected in place per inspector requirements.
5. Concrete shall be Class 420-C-2000.

		MIDWAY CITY SANITARY DISTRICT WESTMINSTER, CA.	SEWER - STORM DRAIN CROSSING	NO SCALE
		<i>Kenneth ...</i> 11/2/2010		STANDARD DWG.
NO.	APPROVED	DATE		S-011

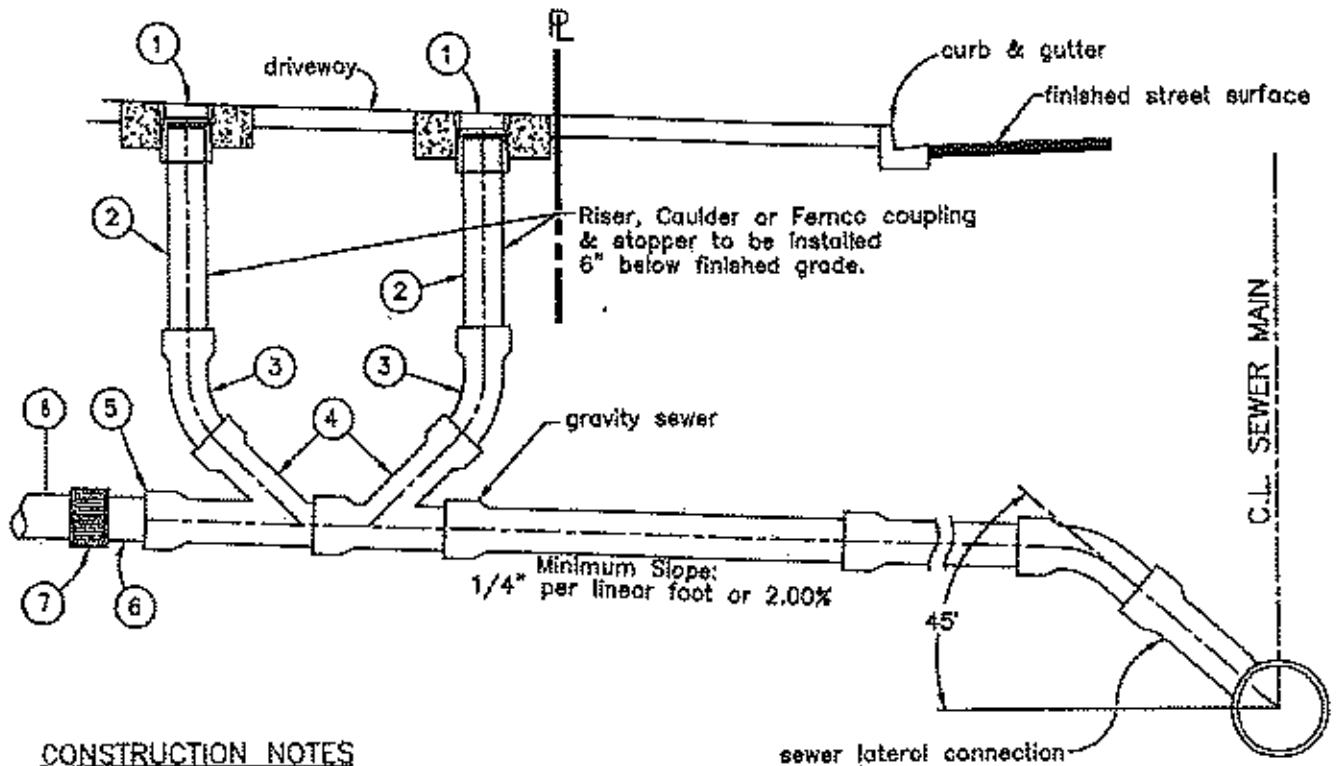

CONSTRUCTION NOTES

- ① Install sewer cleanout cover traffic rated.
- ② 4" (or 6") SDR-35 PVC sewer pipe with gasketed, integral bell and spigot joints.
- ③ 4" (or 6") SDR-35 PVC 45° bend.
- ④ 4" x 4" (or 6" x 6") SDR-35 PVC wye branch fitting.
- ⑤ 4" (or 6") ABS stopper (where laterals are stubbed)
- ⑥ 4" (or 6") short piece, SDR-35 PVC, 6-inches long.
- ⑦ 4" (or 6") rubber mechanical bonded seal clamp, Fernco or approved equal.
- ⑧ 4" (or 6") private sewer lateral.

GENERAL NOTES

- 1 Minimum slope for 4" or 6" sewer lateral shall be 1/4" per foot unless authorized.
- 2. Sewer cleanout shall include a stopper over risers. Use Mission Clay products stopper or equal.
- 3. Sewer cleanout riser pipe material shall be 4" or 6" VCP, ABS, SDR-35.
- 4. A cleanout shall be installed on all sewer lateral connections.
- 5. PVC shall be SDR-35 per ASTM 3034.
- 6. PVC pipe and fittings shall be bedded with 3/4" aggregate base rock material.
- 7. Where VCP materials are used, bedding shall be 3/4" aggregate base rock material.

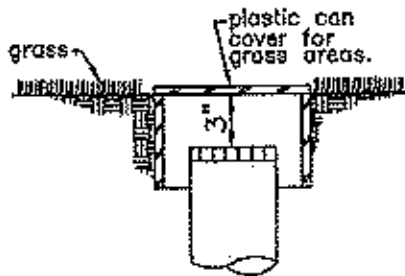

DETAIL-UNPAVED AREA

		MIDWAY CITY BANITARY DISTRICT WESTMINSTER, CA.		2 WAY CLEAN OUT ON PRIVATE PROPERTY		NO SCALE	
		<i>Henry R. ...</i> 11/20/2010				STANDARD DWG.	
NO.	APPROVED	DATE					S-012

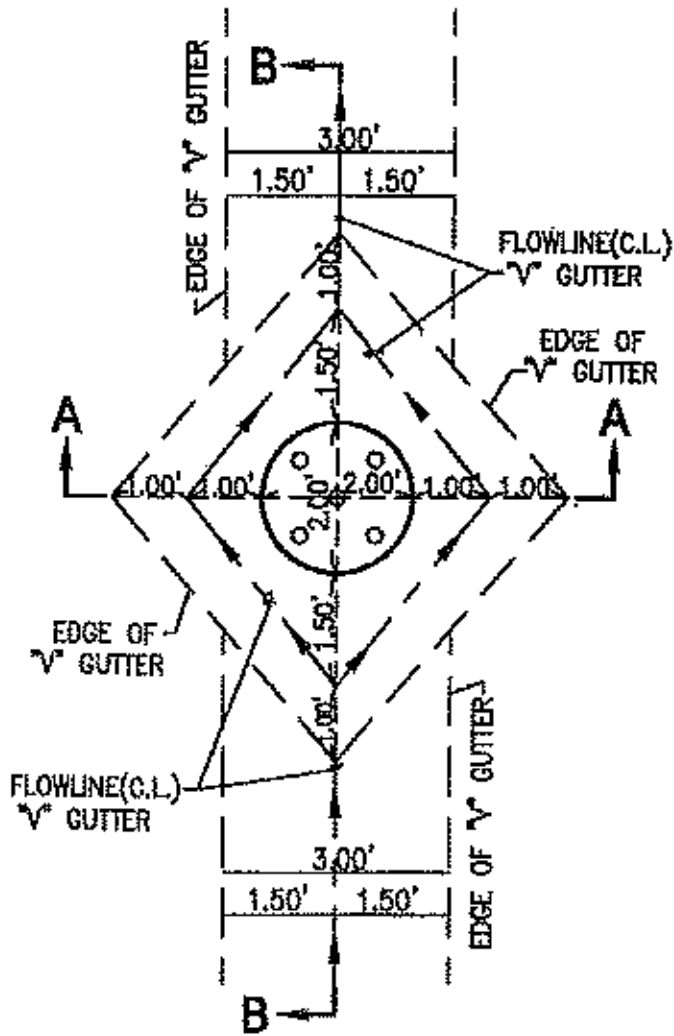

PLAN

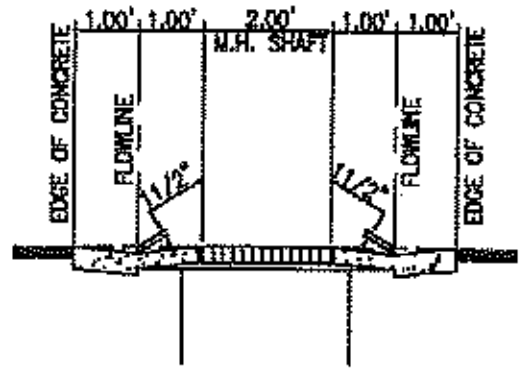

SECTION A-A

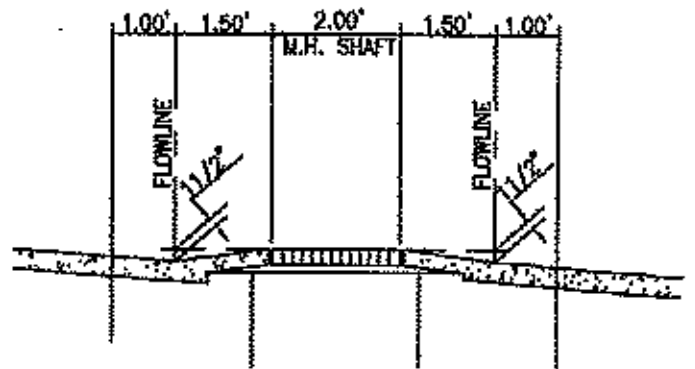

SECTION B-B

		MIDWAY CITY SANITARY DISTRICT WESTMINSTER, CA.		RAISED SEWER MANHOLE IN ALLY GUTTER		NO SCALE	
		<i>[Signature]</i> 11/2/2010				STANDARD DWG.	
NO.	APPROVED	DATE				S-013	

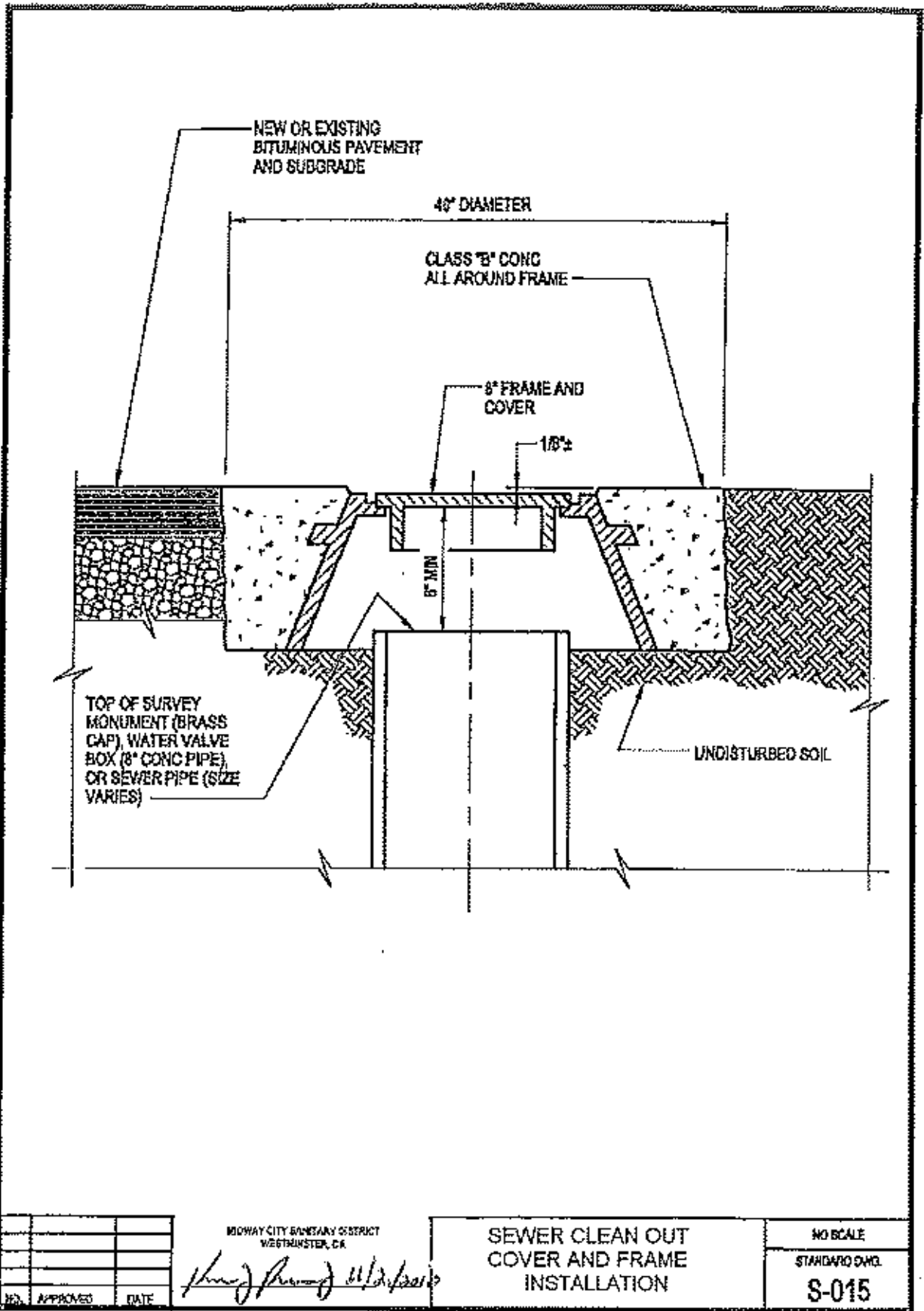

NO.	APPROVED	DATE

MIDWAY CITY SANITARY DISTRICT
 WESTMINSTER, CA
[Signature]

SEWER CLEAN OUT
 COVER AND FRAME
 INSTALLATION

NO SCALE
 STANDARD DWG.
 S-015

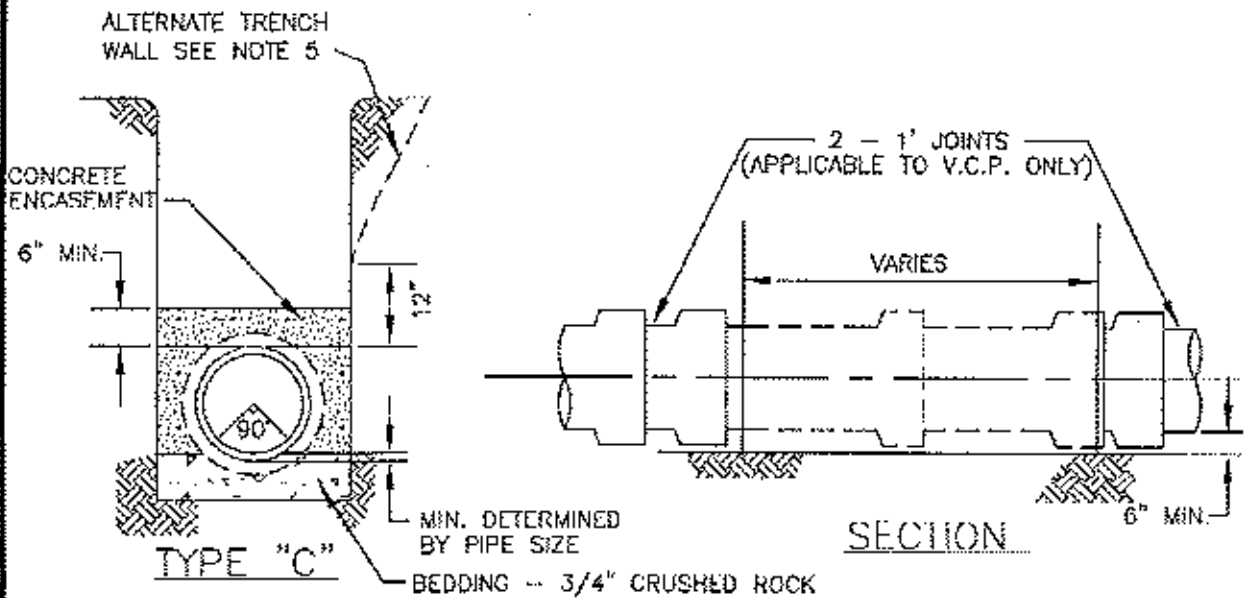
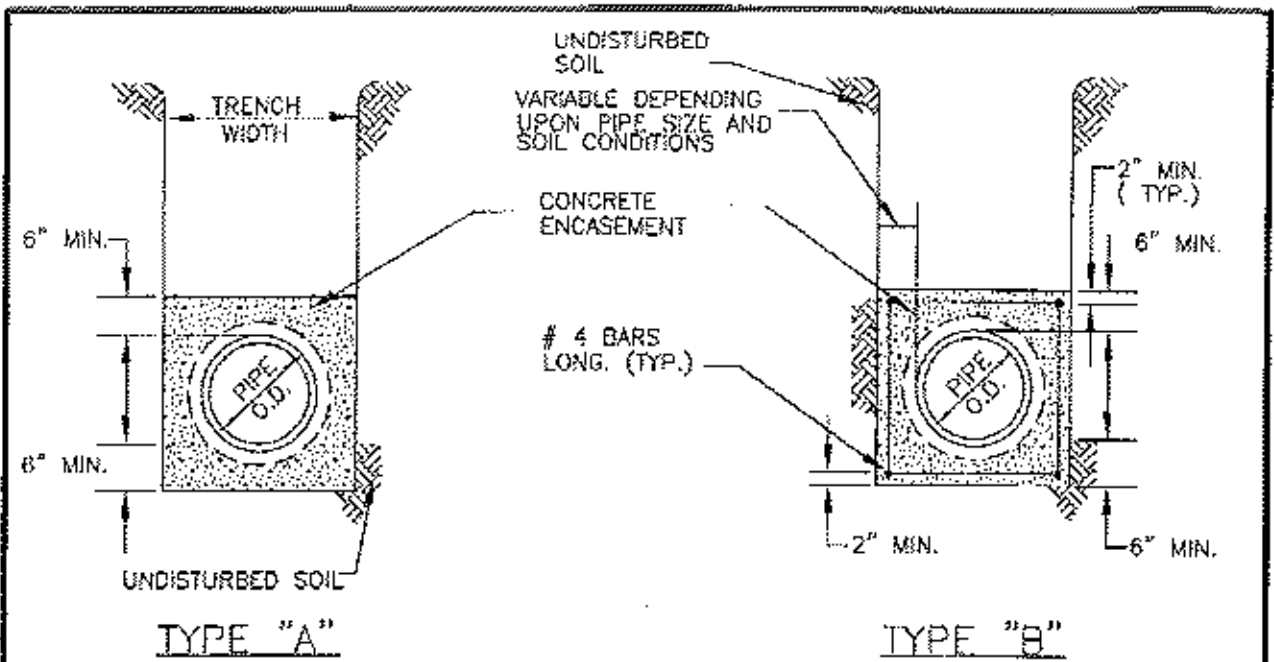

NOTES:

1. CONCRETE ENCASEMENT SHALL BE USED WHEN COVER IS UNDER 4' OR OVER 20'.
2. ENCASEMENT TO BE PLACED AGAINST UNDISTURBED NATURAL GROUND OR FILL COMPACTED TO 90% RELATIVE DENSITY.
3. NO. 4 STEEL REINFORCING BARS SHALL BE USED AS SPECIFIED.
4. TYPE OF CONCRETE ENCASEMENT TO BE USED WILL BE SHOWN ON PLANS OR AS SPECIFIED BY DISTRICT REPRESENTATIVE TO MEET UNFORSEEN FIELD CONDITIONS. UNLESS NOTED OTHERWISE, ENCASEMENT SHALL BE CLASS "B" CONCRETE.
5. WHERE SLOPED TRENCHES ARE USED, WALLS WILL NOT BEGIN TO SLOPE CLOSER THAN 12" FROM THE TOP OF THE PIPE.

REDWAY CITY SANITARY DISTRICT
WESTMINSTER, CALIFORNIA

Handwritten signature and date: 11/2/2016

**CONCRETE ENCASEMENT
TYPE A, B, & C**

NO SCALE

STANDARD DWG.

S-018

BASIC SEPARATION STANDARDS

1. PARALLEL CONSTRUCTION: THE HORIZONTAL DISTANCE BETWEEN PRESSURE DOMESTIC WATER AND RECLAIMED WATER MAINS AND SEWER LINES SHALL BE AT LEAST 10 FEET.
2. PERPENDICULAR CONSTRUCTION (CROSSING): PRESSURE WATER MAINS SHALL BE AT LEAST ONE FOOT ABOVE SANITARY SEWER AND RECLAIMED WATER LINES WHERE THESE LINES MUST CROSS.
3. SPECIAL PROVISIONS: ALTERNATIVE CONSTRUCTION CRITERIA WHERE THE BASIC SEPARATION STANDARDS CANNOT BE ATTAINED ARE SHOWN BELOW:

SITUATION:

LOCATION OF NEW SEWER & RECLAIMED WATER LINES TO EXISTING DOMESTIC & RECLAIMED WATER LINES.

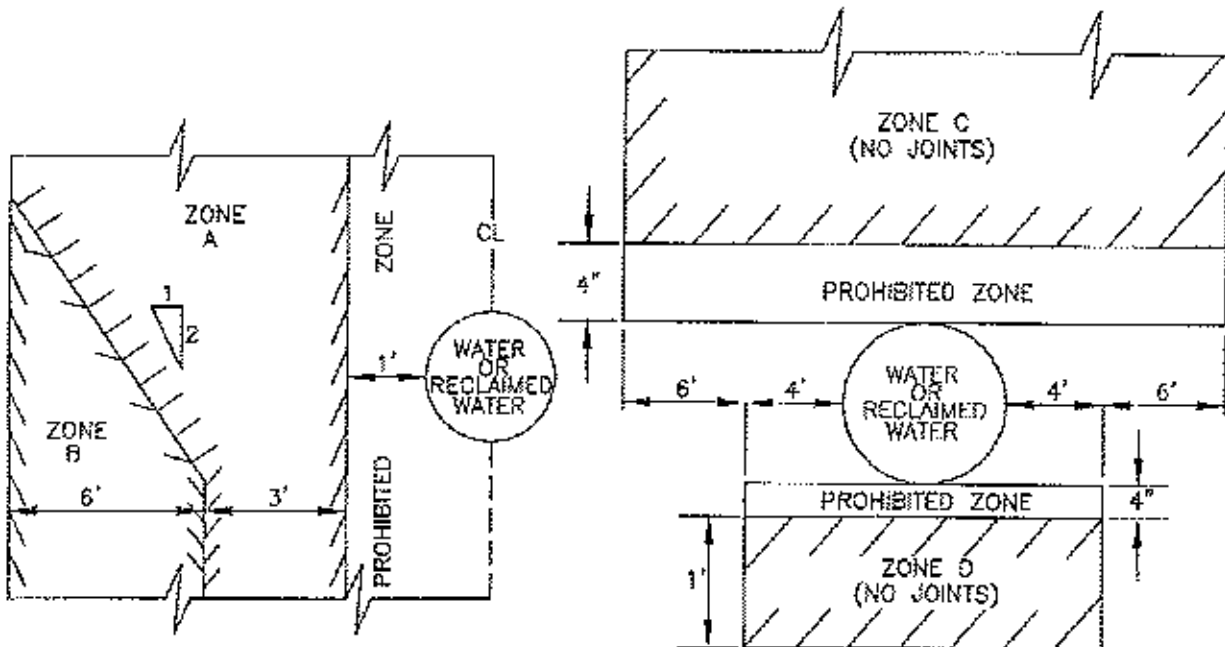

PARALLEL CONSTRUCTION

PERPENDICULAR CROSSING

IF ANY SEWER OR RECLAIMED WATER PIPELINES ARE TO BE CONSTRUCTED WITHIN ANY OF THE ABOVE INDICATED ZONES, SPECIAL CONSTRUCTION SHALL BE REQUIRED AS DESCRIBED BELOW.

ZONE SEWER

RECLAIMED WATER

- | | | |
|---|--|--|
| A | DO NOT LOCATE ANY PARALLEL SEWER OR RECLAIMED WATER LINES IN THIS AREA WITHOUT STATE AND LOCAL HEALTH DEPARTMENT APPROVAL. | |
| B | USE V.C.P. OR D.I.P. WITH COMPRESSION JOINTS. | USE D.I.P. OR CLASS 200 P.V.C. - AWWA C900 |
| C | USE D.I.P. WITH MECHANICAL JOINTS OR CLASS 200 P.V.C. - AWWA C900 | USE D.I.P. OR CLASS 200 P.V.C. - AWWA C900 |
| D | USE D.I.P. OR CLASS 200 P.V.C. - AWWA C900 | USE D.I.P. OR CLASS 200 P.V.C. - AWWA C900 |

MIDWAY CITY SANITARY DISTRICT
WESTMINSTER, CALIFORNIA

PIPELINE SEPARATION
REQUIREMENTS
SHEET 1 OF 2

NO SCALE

STANDARD DWG.

S-019

Handwritten signature and date: 11/2/2010

GENERAL NOTES

1. NO PIPE JOINTS SHALL BE PERMITTED WITHIN ZONE D. IT IS THE INTENT OF THESE SPECIFICATIONS THAT NO JOINTS SHALL OCCUR WITHIN ZONE C. IF THAT CANNOT BE ACCOMPLISHED, THE NEW PIPELINE SHALL BE ENCASED IN CONCRETE FOR THE FULL LENGTH OF ZONE C. ENCASEMENT SHALL BE PER STD. DWG. S-018, TYPE "B"
2. ALL D.I.P. MUST HAVE HOT DIP BITUMINOUS COATING AND ALL CLASS 200 P.V.C. MUST MEET DR-14 PER AWWA C900 OR EQUIVALENT.
3. SEWER FORCE MAINS SHALL NOT BE PERMITTED IN ZONES A THROUGH D.
4. THIS CRITERIA DOES NOT APPLY FOR A RECLAIMED WATER LINE CROSSING ANOTHER RECLAIMED WATER LINE.
5. THE CONSTRUCTION CRITERIA APPLY TO HOUSE LATERALS THAT CROSS ABOVE A PRESSURE WATER MAIN BUT NOT TO THOSE HOUSE LATERALS THAT CROSS BELOW A PRESSURE WATER MAIN.

SITUATION:

LOCATION OF NEW & RECLAIMED WATER LINES TO EXISTING SEWER & RECLAIMED WATER LINES.

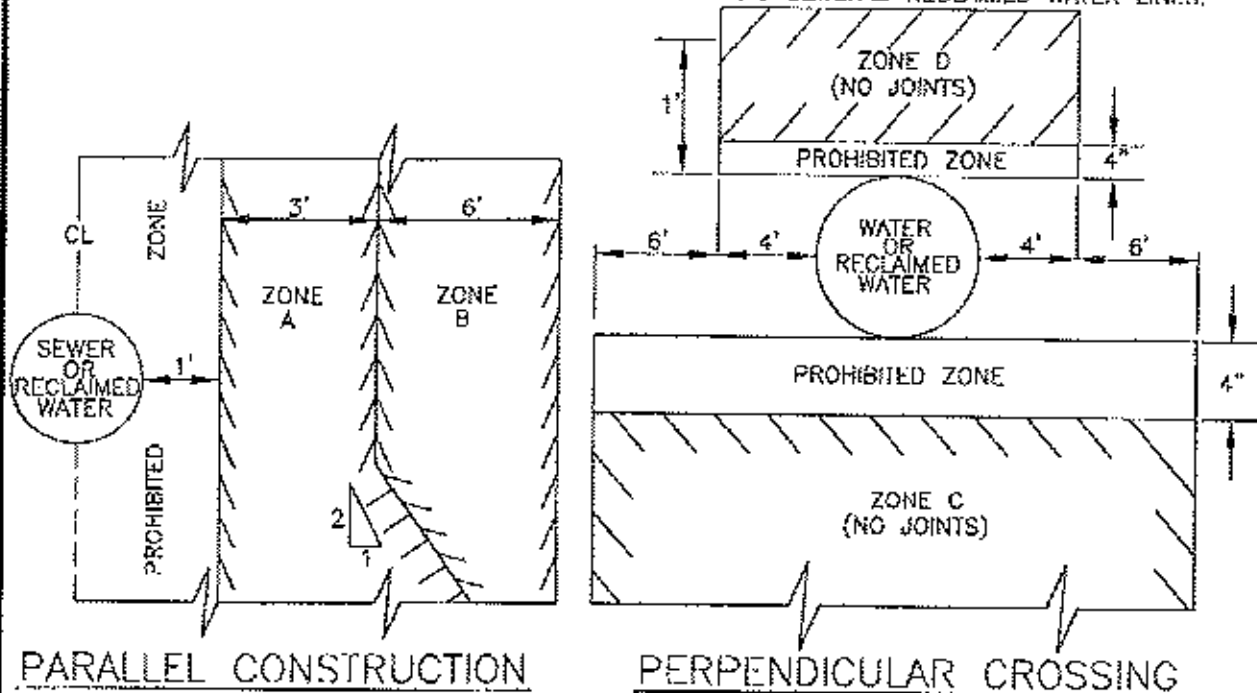

PARALLEL CONSTRUCTION

PERPENDICULAR CROSSING

IF ANY WATER OR RECLAIMED WATER PIPELINES ARE TO BE CONSTRUCTED WITHIN ANY OF THE ABOVE INDICATED ZONES, SPECIAL CONSTRUCTION SHALL BE REQUIRED AS DESCRIBED BELOW.

ZONE DOMESTIC WATER OR RECLAIMED WATER

- A DO NOT LOCATE ANY PARALLEL DOMESTIC WATER OR RECLAIMED WATER MAIN IN THIS AREA WITHOUT STATE AND LOCAL HEALTH DEPARTMENT APPROVAL.
- B USE D.I.P. OR CLASS 200 P.V.C. - AWWA C900
- C USE D.I.P. OR CLASS 200 P.V.C. - AWWA C900
- D USE D.I.P. OR CLASS 200 P.V.C. - AWWA C900

MIDWAY CITY SANITARY DISTRICT
WESTMINSTER, CALIFORNIA

Handwritten signature and date: 11/01/2010

PIPELINE SEPARATION
REQUIREMENTS
SHEET 2 OF 2

NO SCALE

STANDARD DWG.

S-019

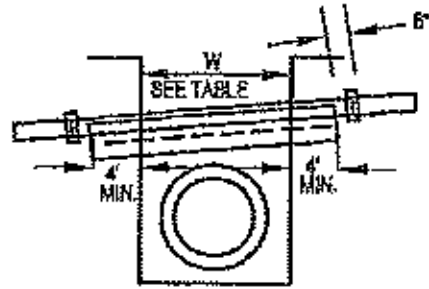
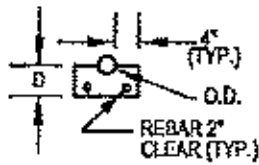
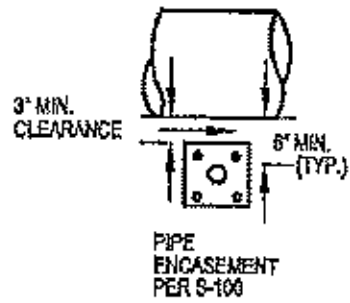
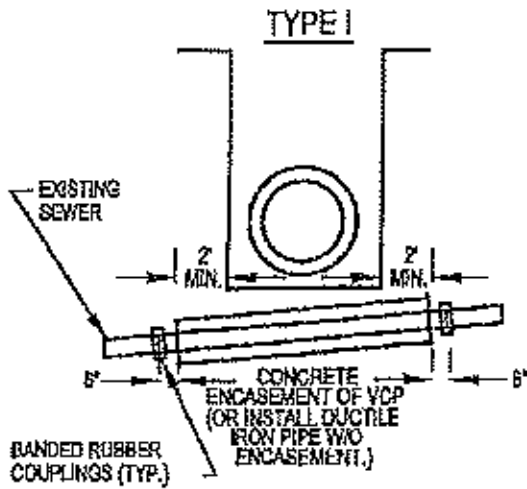

TYPE II

W	DEPTH OF COVER			
	6' TO 8'		8' TO 15'	
	D	BAR #	D	BAR #
3'	12"	4(13)	12"	4(13)
4'	12"	4(13)	12"	5(16)
5'	12"	4(13)	15"	5(16)
6'	12"	5(16)	15"	5(16)
7'	12"	5(16)	15"	6(19)
8'	12"	5(16)	15"	6(19)
9'	12"	6(19)	15"	6(25)
10'	12"	6(19)	15"	6(25)

NOTE:

() DENOTES METRIC SYSTEM.

NO.	APPROVED	DATE

MIDWAY CITY SANITARY DISTRICT
VICKSBURG, CA

Handwritten signature and date: 11/3/2016

PIPE SUPPORT
BEAM
ACROSS TRENCHES

NO SCALE
STANDARD DWS
S-020

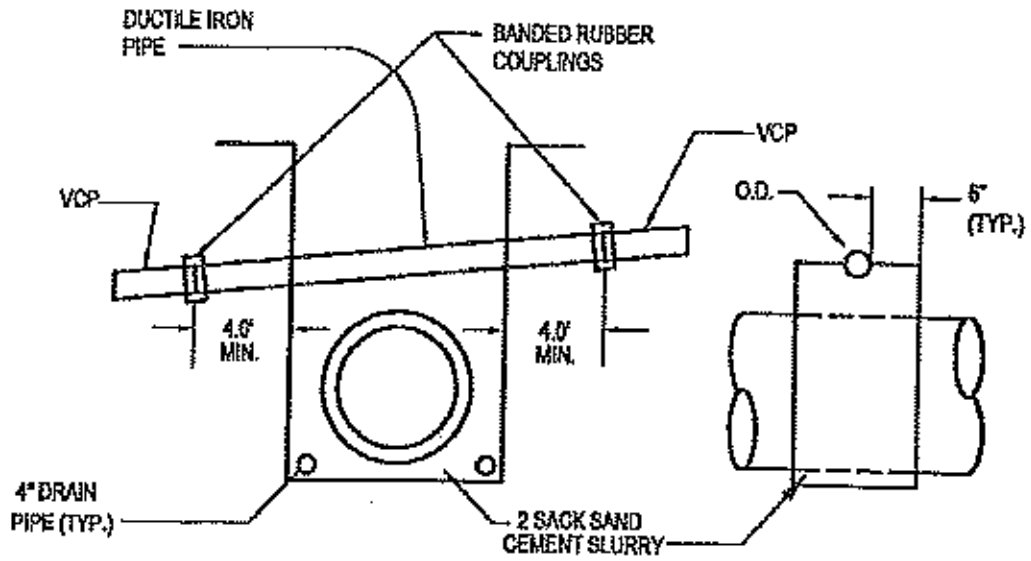

NOTE:

THIS DETAIL MAY BE USED ONLY WITH PRIOR APPROVAL OF THE DISTRICT ENGINEER.

NO.	APPROVED	DATE

970 WAY CITY SANITARY DISTRICT
WESTMINSTER, CA

Henry Henry 11/21/2010

PIPE SUPPORT
WALL
ACROSS TRENCHES

NO SCALE
STANDARD DWG.
S-021

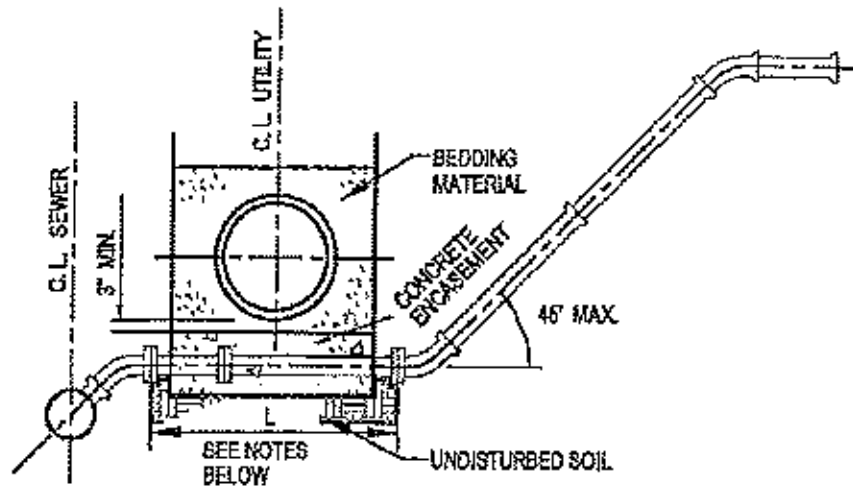

TYPE I

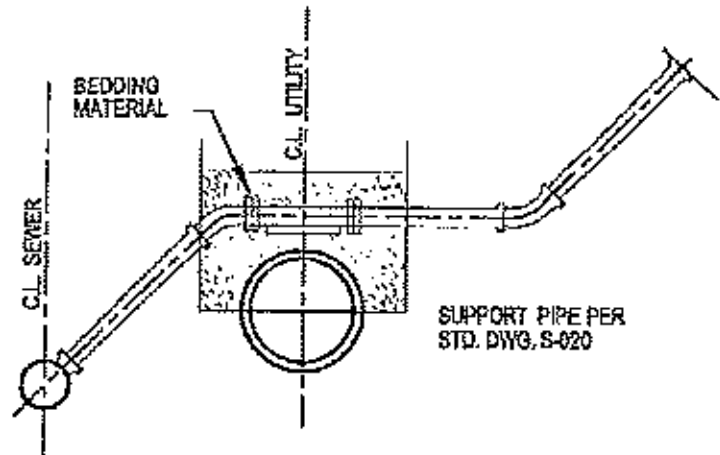

TYPE II

NOTES:

1. ANY OTHER PROPOSED DESIGN SHALL HAVE THE DISTRICT ENGINEER'S APPROVAL PRIOR TO THE START OF CONSTRUCTION.
2. MINIMUM SLOPE FOR SEWER LATERAL SHALL BE 1/4" PER FOOT.
3. L= WIDTH OF STORM DRAIN TRENCH PLUS EXTENSION AT BOTH SIDES TO FIRST PIPE JOINT AT OR BEYOND TRENCH.
4. LATERALS SHALL HAVE A MINIMUM OF 5' OF COVER AT THE PROPERTY LINE.
5. ALL ENCASED SEWER PIPE SHALL BE DUCTILE IRON WITH BANDED RUBBER COUPLINGS.
6. ALL ENCASEMENTS SHALL BE CLASS 'A' CONCRETE.

NO.	APPROVED	DATE

MOJAVE CITY SANITARY DISTRICT
WESTPHALIA, CA
Handwritten signature and date: 11/2/2000

SEWER HOUSE
LATERAL AT
UTILITY INTERSECTIONS

NO SCALE
STANDARD DWG.
S-022

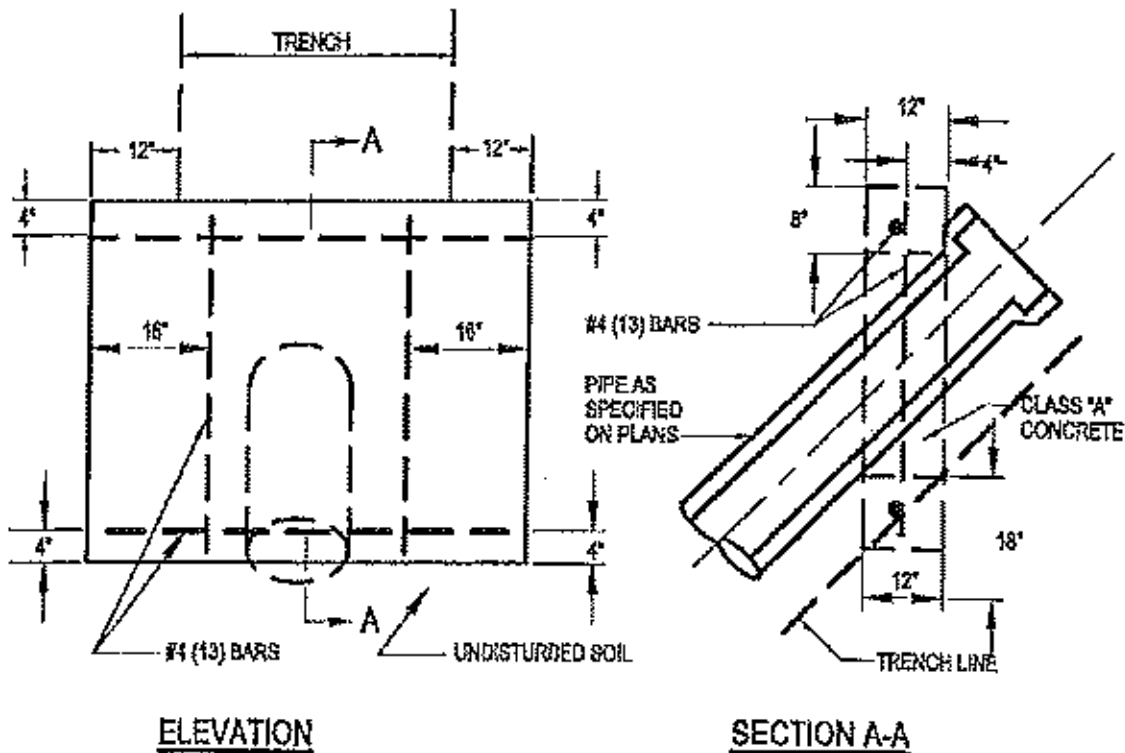

NOTES:

1. PIPE ANCHOR BLOCKS SHALL BE INSTALLED ON ALL SEWERS WHERE THE SLOPE EXCEEDS 30%.
2. SPACING SHALL BE 100' ON CENTER WHERE SLOPES ARE 30% TO 50%, 75' ON CENTER WHERE SLOPES ARE 51% TO 70% AND 50' ON CENTER WHERE SLOPES ARE 71% AND GREATER.
3. THE ENGINEER MAY REQUIRE DUCTILE IRON PIPE WITH MECHANICAL JOINTS IN LIEU OF ANCHOR BLOCKS.

() DENOTES METRIC SYSTEM.

NO.	APPROVE	DATE

MIDWAY CITY SANITARY DISTRICT
WESTMINSTER, CA

[Handwritten Signature]

ANCHOR
BLOCK
DETAIL

NO SCALE
STANDARD DRG
S-023

V.C.P. SIZE	MIN. CASING SIZE	MIN. WALL THICKNESS
6"	16" I.D.	1/4"
8"	18" I.D.	1/4"
10"	21" I.D.	5/16"
12"	24" I.D.	5/16"

P.V.C. SIZE	MIN. CASING SIZE	MIN. WALL THICKNESS
6"	12" I.D.	1/4"
8"	16" I.D.	1/4"
10"	18" I.D.	5/16"
12"	20" I.D.	5/16"

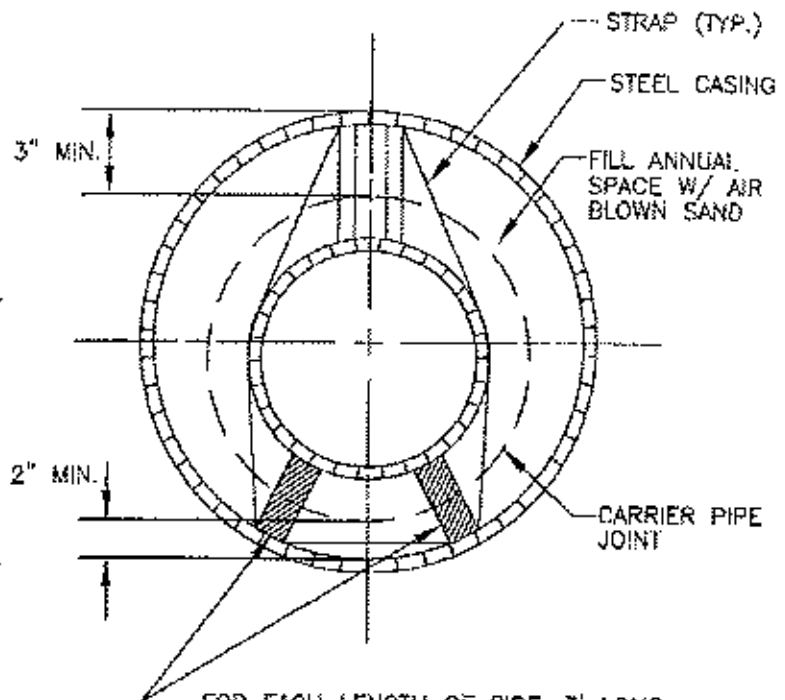

FOR EACH LENGTH OF PIPE, 3' LONG
4" X 4" SKIDS BEVELED AT BOTH ENDS,
SHALL BE STRAPPED IN PLACE 3" FROM EACH
END OF PIPE. NOTCH SKID TO SEAT STRAP.
STRAP SHALL BE 316 STAINLESS STEEL.

NOTES:

1. UNLESS NOTED OTHERWISE, CASING SHALL BE INSTALLED BY THE BORE, JACK AND/OR TUNNEL METHOD.
2. SIZE AND THICKNESS OF CASING SHALL BE AS SHOWN IN SCHEDULE.
3. ALL STEEL CASING PIPE FIELD JOINTS SHALL BE WELDED FULL-CIRCUMFERENCE.
4. UNFINISHED 4" X 4" REDWOOD SKIDS SHALL BE PROVIDED PER DETAIL ABOVE.
5. CARRIER PIPE SHALL BE AIR PRESSURE TESTED PRIOR TO FILLING CASING.
6. UPSTREAM AND DOWNSTREAM ELEVATIONS OF CARRIER PIPE TO BE VERIFIED PRIOR TO FILLING.
7. EACH END OF CASING SHALL BE SEALED WITH CONCRETE MORTAR.
8. INSTALL GROUT CONNECTIONS TO CASING AND GROUT TO FILL ALL VOIDS.

MIDWAY CITY SANITARY DISTRICT
WESTMINSTER, CALIFORNIA

Handwritten signature

STEEL PIPE CASING

NO SCALE

STANDARD DWG.

S-030A

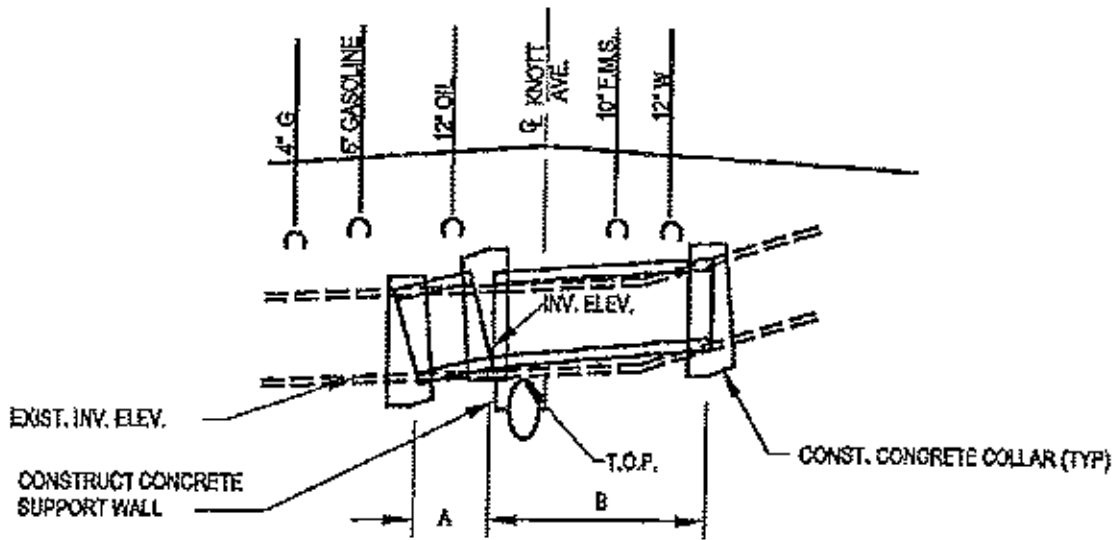

TYPICAL PROFILE
NO SCALE

NOTES:

1. A CONCRETE COLLAR IS REQUIRED WHERE THE CHANGE IN GRADE EXCEEDS 0.10 FEET PER FOOT.
2. WHERE PIPES OF DIFFERENT DIAMETERS ARE JOINED WITH A CONCRETE COLLAR, L AND T SHALL BE THOSE OF THE LARGER PIPE D=D1 OR D2, WHICHEVER IS GREATER.
3. FOR PIPE SIZE NOT LISTED USE NEXT SIZE LARGER.
4. OMIT REINFORCING ON PIPES 24" AND LESS IN DIAMETER AND ON ALL PIPES WHERE ANGLE CHANGE IS LESS THAN 0.10 FEET PER FOOT.
5. WHERE REINFORCING IS REQUIRED THE DIAMETER OF THE CIRCLE TIES SHALL BE $D + (2 \times \text{WALL THICKNESS}) + 8$.
6. WHEN D1 IS EQUAL TO OR LESS THAN D2, JOIN INVERTS AND WHEN D1 IS GREATER THAN D2, JOIN SOFFITS.
7. NOT TO BE USED FOR A SIZE CHANGE ON THE MAINLINE.
8. USE CLASS "A" CONCRETE.
9. DIMENSIONS A,B, ELEVATIONS AND SLOPES (S=0....) SHALL BE SHOWN ON THE PLANS.
10. THE INSIDE OF THE FIELD CLOSURE SHALL BE BARREL FORMED UTILIZING T-LOCK PVC AND ANGLE TURNBACKS AT EDGES, CAULK EDGES OF PVC.

() DENOTES METRIC SYSTEM

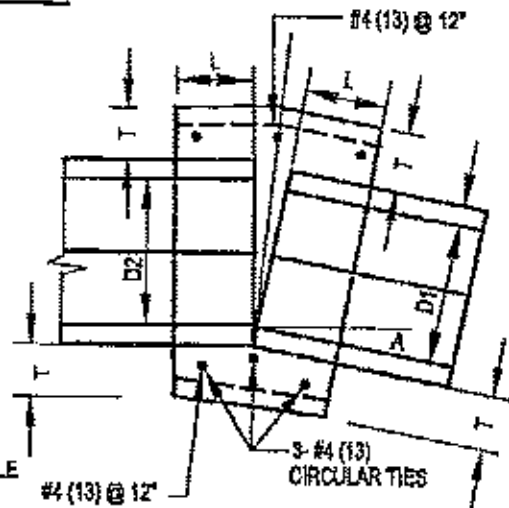

TYPICAL CONCRETE COLLAR
NO SCALE

D	L	T
12"	1.0'	4"
18"	1.0'	5"
24"	1.0'	6"
36"	1.5'	8"
42"	1.5'	9"

NO.	APPROVED	DATE

ROSNAY CITY SANITARY DISTRICT
WESTHIRSTER, CA

Handwritten signature

FIELD CLOSURE
FOR
V.C.P.

NO SCALE
STANDARD DWG.
S-040

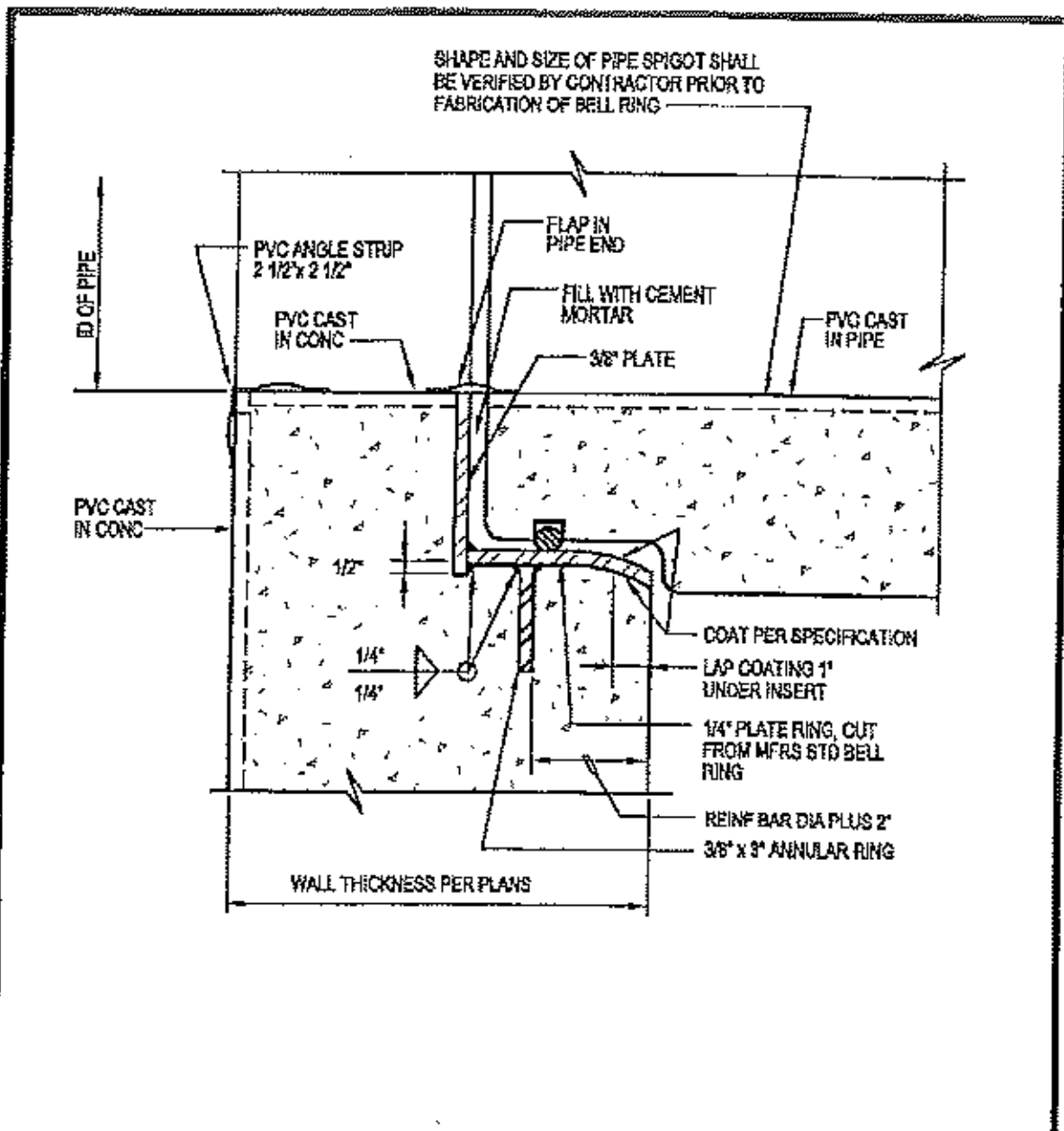

NOTES:

1. WELD ALL CUT REINFORCING BARS TO ANNULAR RING FOR PIPES GREATER THAN 48" DIAMETER. USE LOW HYDROGEN WELDING ER 70XX.
2. GRIND SMOOTH ALL METAL EDGES IN AREAS TO BE COATED AND ALL SURFACES IN PIPE SEATING AREA.
3. RING SHALL HAVE SPIDER BRACING INSTALLED AT POINT OF MANUFACTURE.
4. ALL WELDS SHALL BE DYE TESTED PRIOR TO SHIPMENT.

NO.	APPROVED	DATE

INDUARY CITY SANITARY DISTRICT
WESTMINSTER, CA
Henry Rung 11/2/00

BELL RING INSERT
WITH PVC
PLATE LINER

NO SCALE
STANDARD DWG.
S-044

FRAME AND COVER
PER DWG. S-053

3/4" TO 1"
A.C. PAVING

CLASS "B"
CONCRETE COLLAR

1" MASTIC
JOINT (TYP.)

FACTORY
PLUG

BRICK & MORTAR PLUG

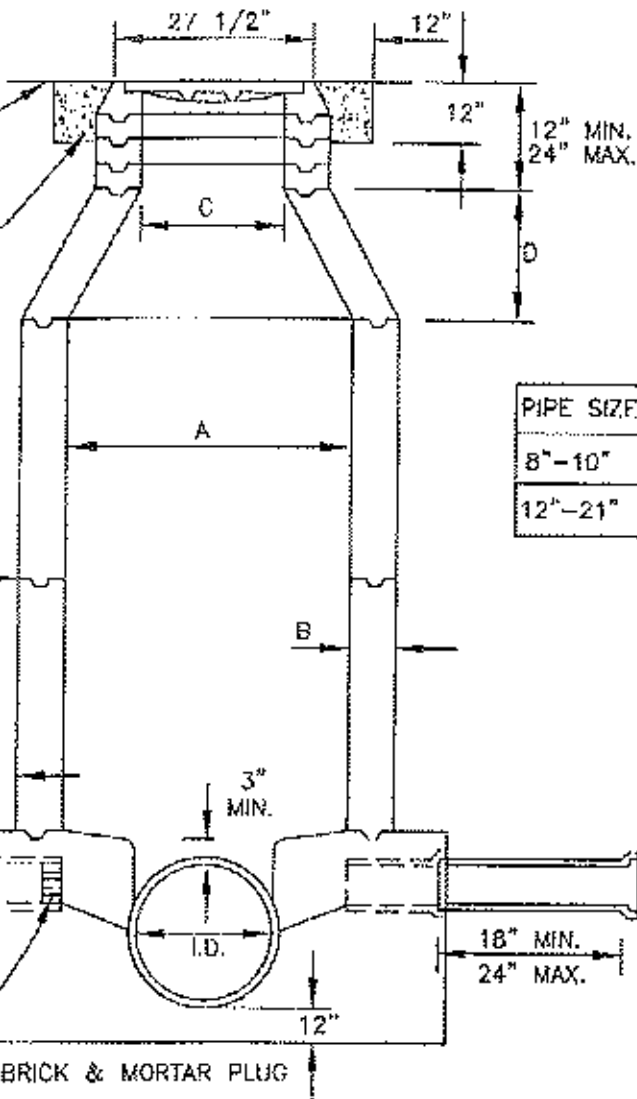

PIPE SIZE	A	B	C	D
8"-10"	48"	6"	24"	24"
12"-21"	60"	8"	36"	24"

NOTES:

1. NO STEPS ARE ALLOWED IN ANY MANHOLE. ALL SHAFTS AND CONES SHALL BE PRECAST. ECCENTRIC CONE SHALL BE SET WITH STRAIGHT SIDE ON THE DOWNSTREAM SIDE OF THE MANHOLE. SHAFT AND CONE MAY BE REINFORCED OR NON-REINFORCED.
2. MANHOLE BASE SHALL BE POURED WITH CLASS "A" CONCRETE.
3. SIDES OF BASE SHALL BE EITHER FORMED OR POURED AGAINST VERTICAL SMOOTH EARTH.
4. CROWN OF LATERAL SHALL MATCH CROWN OF MAIN.
5. MANHOLE PLACED IN UNPAVED AREAS SHALL HAVE THEIR FRAMES AND COVERS SET TO 18" ABOVE FINISHED GRADE.
6. WHEN THE DEPTH OF MANHOLE EXCEEDS 15' FROM THE TOP OF PIPE TO FINISHED GRADE THE MANHOLE SHAFT SHALL BE INCREASED TO A DIAMETER OF 60".

MIDWAY CITY SANITARY DISTRICT
WESTMINSTER, CALIFORNIA

Henry J. ... 11/2/2010

UN-LINED MANHOLE
FOR SEWERS

NO SCALE

STANDARD DWG.

S-045A

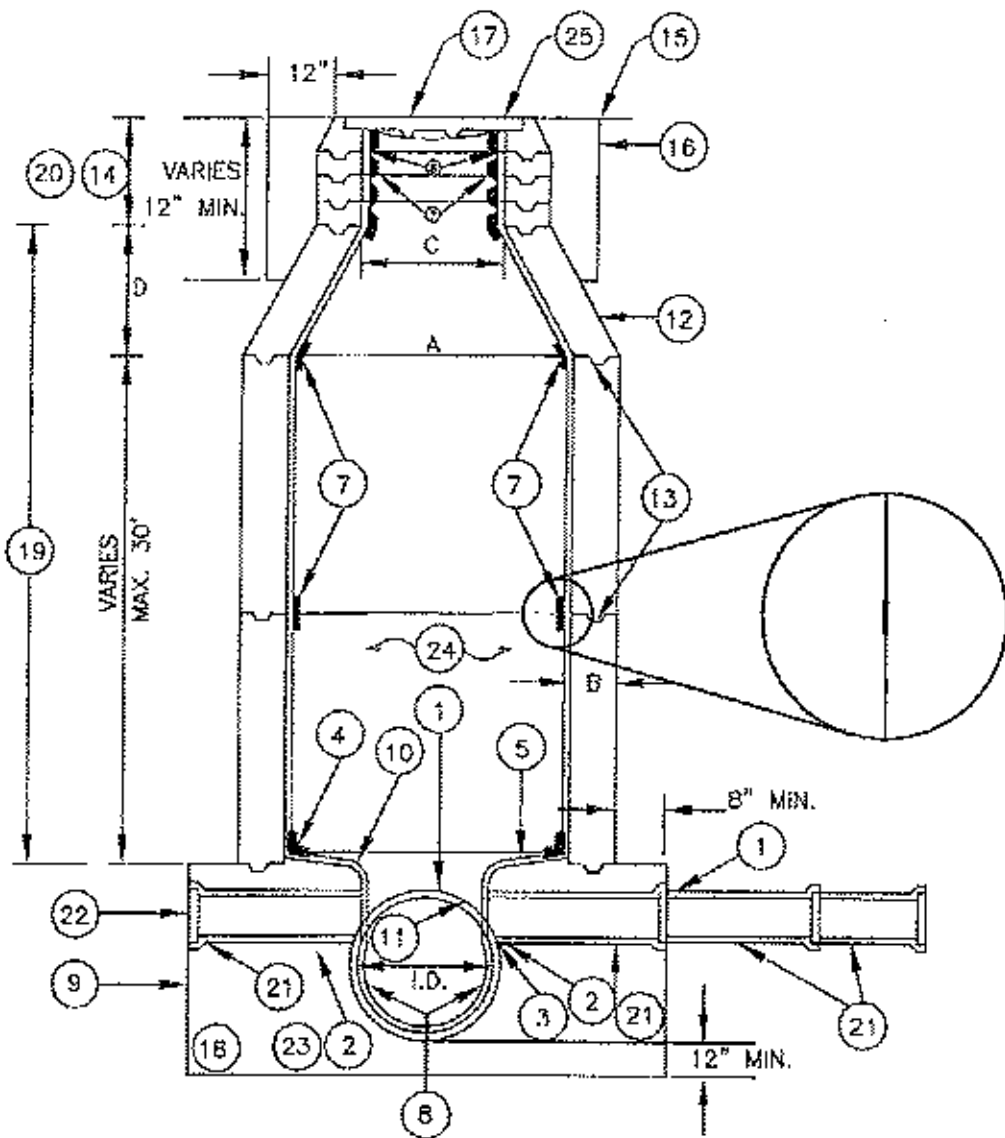

NOTES:

SEE DETAIL S-050A SHEET 3 OF 3
FOR DIMENSION TABLE.

MIDWAY CITY SANITARY DISTRICT
WESTMINSTER, CALIFORNIA

Handwritten signature and date: 11/2/1980

PVC-LINED MANHOLE
FOR SEWERS
SHEET 1 OF 3

NO SCALE

STANDARD DWG.

S-050A

NOTES:

- ① LATERAL SOFFIT SHALL MATCH SOFFIT OF TRUNK SEWER. SEE NOTE 21.
- ② PVC TURNBACK ON VCP SHALL BE A MINIMUM OF 6" PER S-056.
- ③ PVC LINER PLATE SHALL BE HELD TIGHT TO OUTSIDE SURFACE OF VCP BY 1/2" STAINLESS STEEL BAND WITH CONTACT CEMENT ADHESIVE APPLIED TO BOTH SURFACES PER S-056.
- ④ PREFORMED CORNER WELD STRIP TO BE INSTALLED.
- ⑤ INSTALL NON-SKID SURFACE ON COMPLETE MANHOLE SHELF, BOTH SIDES OF MAIN CHANNEL PER THE STANDARD SPECIFICATIONS.
- ⑥ INSTALL CONTINUOUS PREFORMED CORNER PVC ANGLES UNDER FRAME.
- ⑦ PVC WELD STRIPS.
- ⑧ COMPLETE CONCRETE CHANNEL SHALL BE CONSTRUCTED WITH FORMS AND PVC LINED. WHERE PVC LINED RCP IS USED, THE CHANNEL LINING IS TO BE INSTALLED TO THE SAME DEPTH AS THE RCP LINING.
- ⑨ SIDES OF BASE TO BE EITHER FORMED OR Poured NEAT AGAINST UNDISTURBED EARTH. BASE MAY BE EITHER CIRCULAR OR RECTANGULAR.
- ⑩ MANHOLE SHELVES TO BE SLOPED 1" PER FT. TO CHANNEL
- ⑪ ALL LATERAL INLETS 12" DIAMETER AND SMALLER SHALL HAVE PVC WELDED GAS FLAPS INSTALLED PER DRAWING NO. S-056.
- ⑫ ECCENTRIC CONE TO BE SET WITH STRAIGHT SIDE ON DOWNSTREAM SIDE OF MANHOLE FOR MAINTENANCE PURPOSES. ECCENTRIC REINFORCED CONCRETE FLAT TOPS MAY BE USED WHEN APPROVED BY THE ENGINEER THRU SUBMITTAL REVIEW.
- ⑬ 2 WRAPS OF RAM NECK OR APPROVED EQUAL SEALANT. THE SEAL STRIPS SHALL BE PLACED ON SHOULDER OF GROOVE. STEPS ARE NOT ALLOWED IN ANY MANHOLE.
- ⑭ DISTANCE FROM TOP OF CONE TO TOP OF FRAME AND COVER SHALL NOT BE LESS THAN 12" OR MORE THAN 24". ALL GRADE RINGS SHALL BE REINFORCED CLASS V CONCRETE WITH PRECAST PVC LINER PLATE ON INSIDE.
- ⑮ FOR 1" AC PAVING, CONTRACTOR OR DESIGNER SHALL VERIFY WITH LOCAL CITY REQUIREMENTS. SEE S-055.
- ⑯ CONCRETE COLLAR SEE S-055.
- ⑰ FRAME AND COVER PER DRAWING NO. S-053A, S-054-A OR S-055.
- ⑱ MANHOLES 72" AND LARGER SHALL HAVE CLASS "A" CONCRETE BASES W/ #8 (19) @ 12" E.W.
- ⑲ MANHOLES SHALL BE BACKFILLED WITH 1 1/2 SACK SLURRY.

MIDWAY CITY SANITARY DISTRICT
WESTMINSTER, CALIFORNIA

Handwritten signature and date
11/2/2016

PVC-LINED MANHOLE
FOR SEWERS
SHEET 2 OF 3

NO SCALE

STANDARD DWG.

S-050A

NOTES CONTINUED:

- ⑳ MANHOLES PLACED IN UNPAVED AREAS SHALL HAVE THE COVERS PLACED 18" ABOVE FINISHED GRADE.
- ㉑ ALL MANHOLES SHALL HAVE TWO 8" VCP STUBS SLOPED 1/4" PER FOOT INSTALLED AT 90° TO THE MAIN CHANNEL EXCEPT WHERE THE MAIN CHANNEL MAKES A TURN OF OVER 45°. STUBS SHALL BE 8" MIN. IN DIA. UNLESS OTHERWISE NOTED.
- ㉒ ALL UNUSED CONNECTIONS SHALL HAVE A FACTORY MADE VCP PLUG INSTALLED IN THE BELL END OF THE PIPE AND A BRICK AND MORTAR PLUG IN THE SPIGOT END OF THE CONNECTION TO THE MAIN TRUNK SEWER CHANNEL. EACH VCP CONNECTION TO THE MANHOLE BASE SHALL HAVE TWO EACH, TWO FOOT JOINTS.
- ㉓ PIPE ABOVE SPRING LINE TO BE REMOVED BY SAW CUTTING, REMOVED SECTION SHALL BE THE MANHOLE SHAFT DIAMETER.
- ㉔ INSTALLATION OF P.V.C. LINER PLATE SHALL CONFORM TO THE REQUIREMENTS OF SECTION 06620 OF THE MASTER SPECIFICATIONS OF THE ORANGE COUNTY SANITATION DISTRICT.
- ㉕ SEAL MANHOLE COVERS AS PER SPECIFICATIONS FOR MINIMIZING ODOR OR INFLOW.
- ㉖ VACUUM TESTING SHALL BE PERFORMED PER ASTM C-1224 UNO.

◊ DENOTES REINFORCED CROSS SECTION
 ◊◊ DENOTES BASE MUST BE REINFORCED CONCRETE

PIPE SIZE	A	B	C	D
8"-10"	48"	8"	26"	24"
		6"		
12"-24"	60"	8"	36"	24"
		6"		

MIDWAY CITY SANITARY DISTRICT
 WESTMINSTER, CALIFORNIA
[Signature] 11/20/2010

PVC-LINED MANHOLE
 FOR SEWERS
 SHEET 3 OF 3

NO SCALE
 STANDARD DWG.
 S-050A

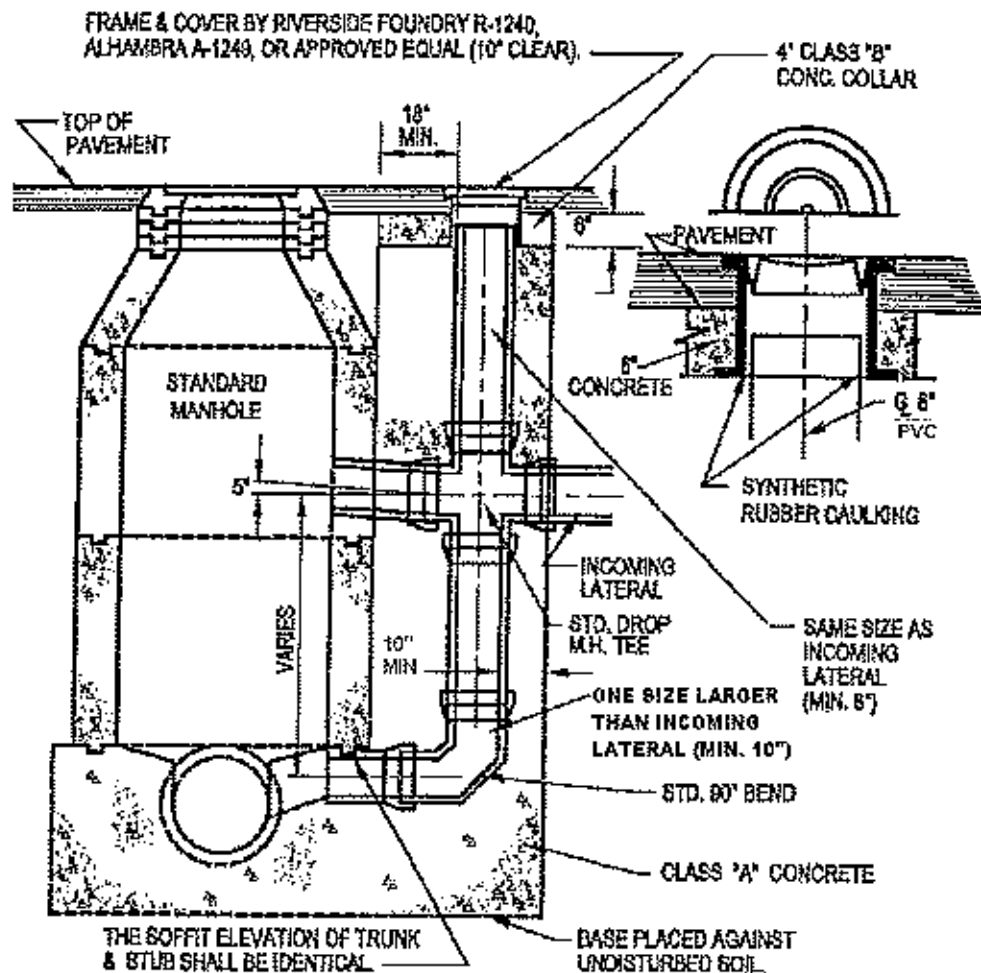

NOTES:

1. SEE DETAIL S-050 FOR STANDARD MANHOLE.
2. CONCRETE FOR DROP SECTIONS SHALL BE FORMED.
3. ALL MANHOLE PENETRATIONS SHALL BE MADE BY CORE DRILLING.
4. DROP MANHOLE CONNECTION SHALL BE USED ONLY WHERE SLOPE OF LATERAL INCOMING TO MAIN SEWER WOULD EXCEED 10% AND WITH APPROVAL OF THE THE ENGINEER AND SPECIAL PERMISSION ONLY.

NO.	APPROVED	DATE

MOHAWK CITY SANITARY DISTRICT
WESTCHESTER, CA

Handwritten signature and date: 11/21/2000

DROP MANHOLE
CONNECTION TO
STANDARD MANHOLE

NO SCALE
STANDARD DRG.
S-051

DIAMOND TREAD PATTERN

3" LETTERS (TYP.)

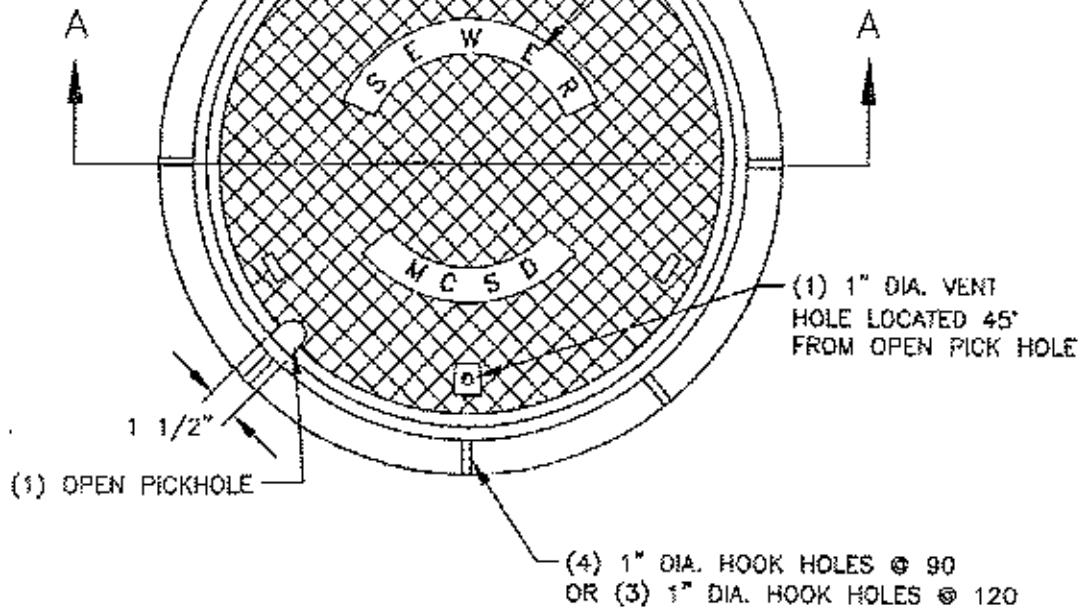

PLAN

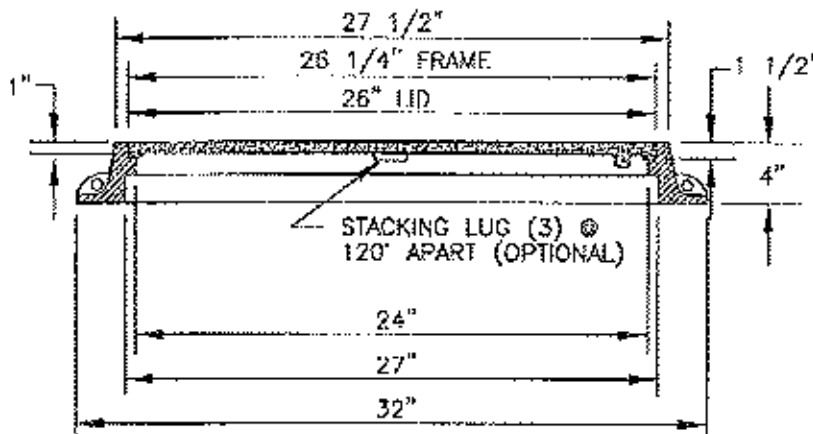

SECTION A-A

NOTE:

- COVERS SHALL BE TRAFFIC GRADE ALHAMBRA A-1270 OR APPROVED EQUAL. ALL CASTINGS SHALL BE COMPLETELY PAINTED WITH 6 MILS. "COAL TAR EPOXY" OR ASPHALT EMULSION, AND LETTERED "MADE IN COUNTRY OF ORIGIN", MARKED WITH MANUFACTURER'S IDENTIFICATION "HEAT NO. ___", "ASTM A-48", AND "CLASS 35B IRON" ON UNDERSIDE OF COVER. WEIGHT OF COVER SHALL BE 300 LBS. MIN.*, WEIGHT OF FRAME SHALL BE 275 LBS. MIN.* *ACTUAL WEIGHTS SHALL BE BETWEEN 95-110% MINIMUM.

MIDWAY CITY SANITARY DISTRICT
WESTMINSTER, CALIFORNIA

Handwritten signature and date: 11/2/2010

STANDARD MANHOLE
FRAME AND COVER

NO SCALE

STANDARD DWG.

S-053A

3/8 x 2 1/2
TYPE 316 S.S. HEX
BOLT W/ WASHERS

(2) C.I. LIFT POCKET
(SEE DETAIL)

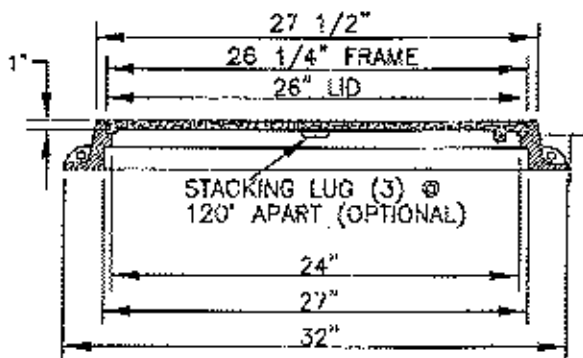
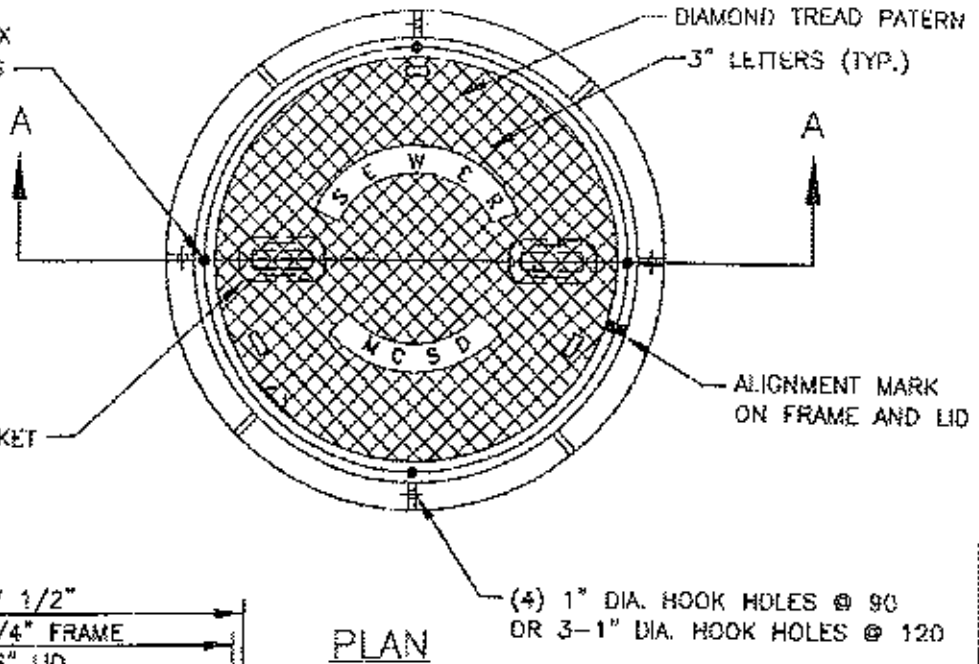

SECTION A-A

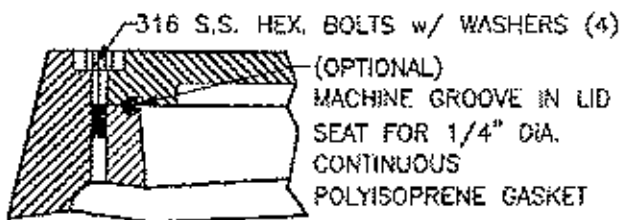

BOLTING/ SELF-SEAL DETAIL

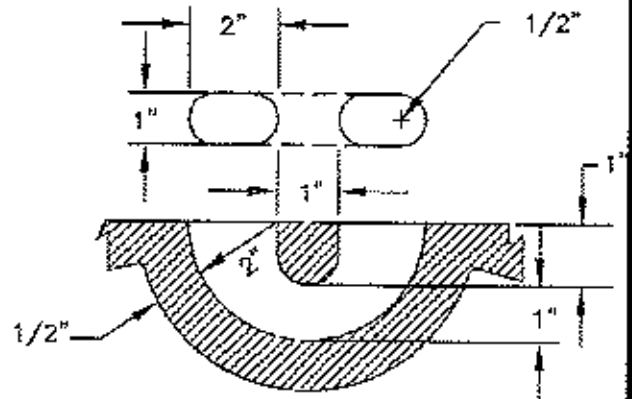

C.I. LIFT POCKET DETAIL

NOTE:

- COVERS SHALL BE TRAFFIC GRADE.
ALL CASTINGS SHALL BE COMPLETELY PAINTED WITH 6 MILS. "COAL TAR EPOXY" OR ASPHALT EMULSION, AND LETTERED "MADE IN COUNTRY OF ORIGIN", MARKED WITH MANUFACTURER'S IDENTIFICATION "HEAT NO. ___", "ASTM A-48", AND "CLASS 35B IRON" ON UNDERSIDE OF COVER WEIGHT OF COVER SHALL BE 300 LBS. MIN.*, WEIGHT OF FRAME SHALL BE 275 LBS. MIN.*
*ACTUAL WEIGHTS SHALL BE BETWEEN 95-110% MINIMUM.
- BOLTED COVERS SHALL BE INSTALLED AT ALL INTERSECTIONS.

MIDWAY CITY SANITARY DISTRICT
WESTMINSTER, CALIFORNIA

Handwritten signature and date: 11/12/2010

BOLTED MANHOLE
FRAME AND COVER

NO SCALE
STANDARD DWG.
S-054A

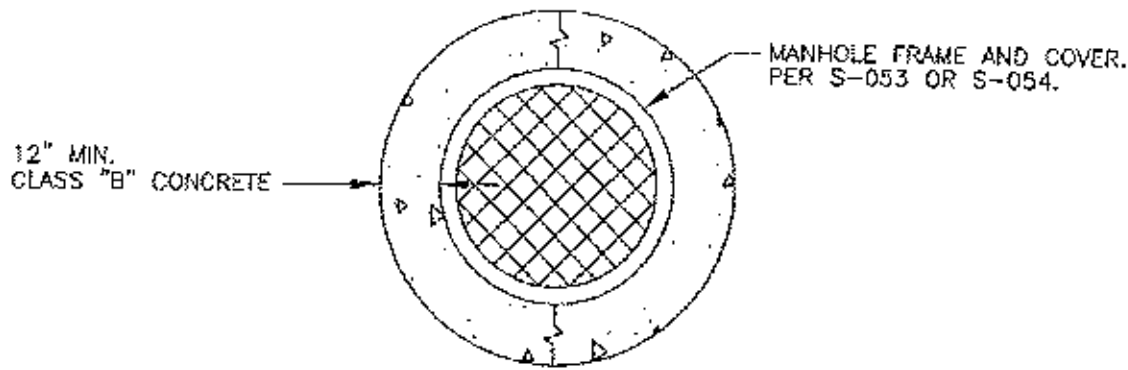

PLAN

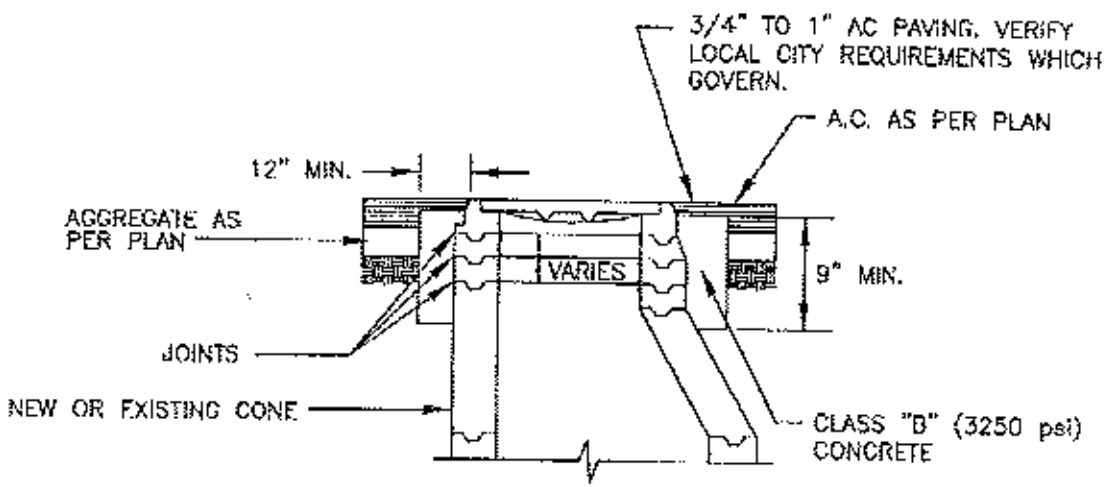

CROSS SECTION

NOTES:

1. ALL AGGREGATE BASE REMOVED SHALL BE REPLACED WITH CLASS B CONCRETE.
2. CONCRETE MAY BE CIRCULAR OR SQUARE IN SHAPE WITH A MINIMUM OF 12" BETWEEN EDGE OF CONCRETE AND UP OF MANHOLE FRAME.
3. MANHOLE MAY BE ADJUSTED TO GRADE USING MORTAR OR PRECAST RINGS. SET FLUSH TO 1/8" HIGH (MAXIMUM).
4. REPAIR PVC OR OTHER LINING, IN KIND.
5. SEAL MANHOLE COVERS AS PER SPECIFICATIONS.
6. REPAIR OR REPLACE MANHOLE LINING IN KIND PER SPECIFICATIONS.

COMPRESSIVE STRENGTH AT 28 DAYS (PSI)	3,250
CEMENT FACTOR MINIMUM (SACK/CU. YD)	5.50
WATER CEMENT RATIO MAXIMUM (GALLONS/SACK)	6.50

MIDWAY CITY SANITARY DISTRICT
WESTMINSTER, CALIFORNIA

Handwritten signature and date: 11/2/2010

MANHOLE ADJUSTMENT
TO GRADE

NO SCALE
STANDARD DRG.
S-055A

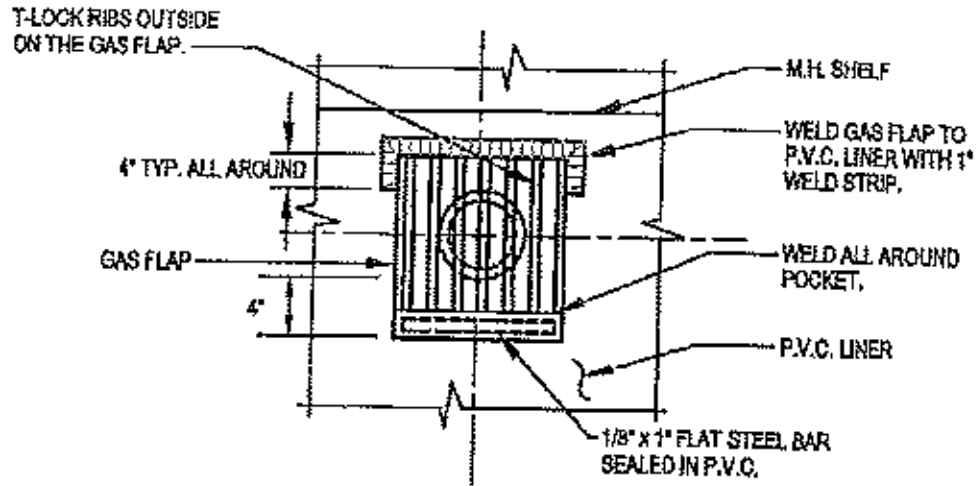

VIEW C-C
NOT TO SCALE

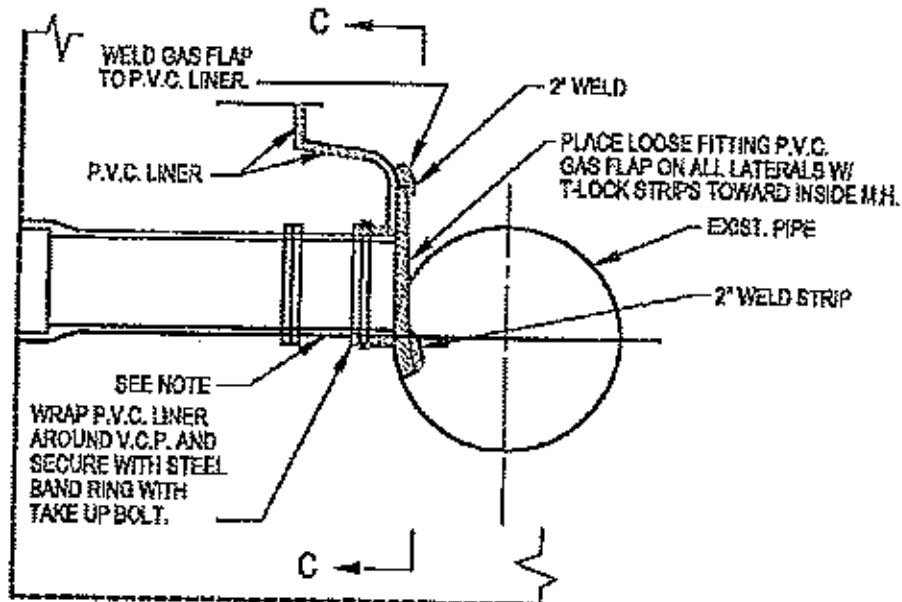

NOTES:

1. FOR INSTALLATION AT EXISTING M.H. REMOVE INTERFERING CONCRETE AT END OF EACH LATERAL AND EXTEND VCP AS SHOWN. GROUT IN PLACE. EXTEND PVC M.H. LINER OVER GROUT AND INSTALL GAS FLAP AS SHOWN.
2. FOR MANHOLES WITHOUT PVC LINER, ATTACH GAS FLAP WITH 1/4" x 1" ST. STL. FLAT BAR AND 3 ST. STL. CA.
3. PROVIDE GAS FLAPS FOR ALL LATERALS 12" AND LESS, UNLESS OTHERWISE SPECIFIED.

NO.	APPROVED	DATE

NOVAY CITY SANITARY DISTRICT
WESTMINSTER, CA

Handwritten signature and date: 11/2/2010

P.V.C. LINER AND GAS
FLAP INSTALLATION
AT LATERALS

NO SCALE
STANDARD DWG.
S-056

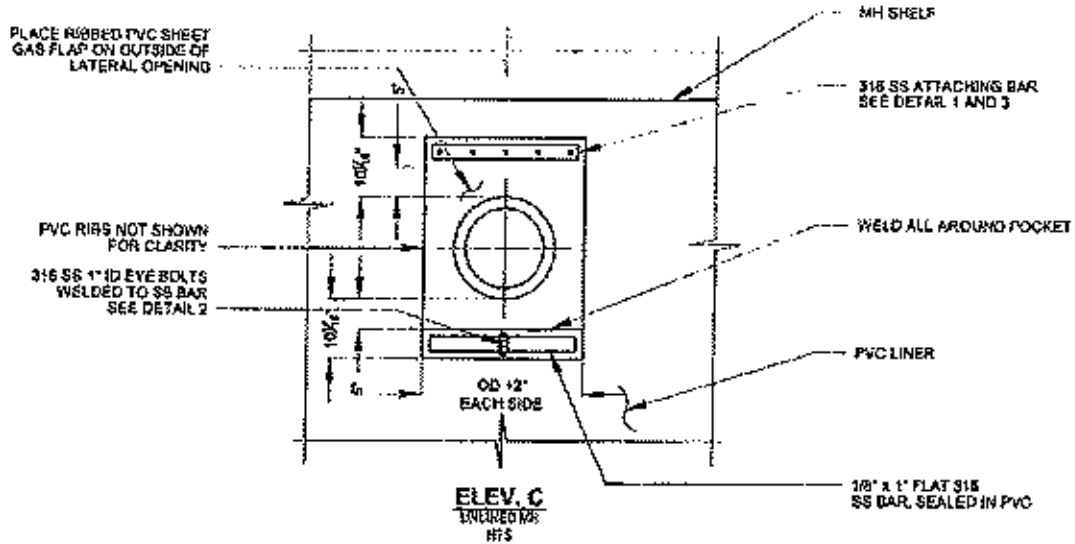

NOTES:

1. FOR INSTALLATION AT EXISTING MH., SEE STD DWG. S-057
2. FOR MANHOLES WITHOUT PVC LINER, ATTACH GAS FLAP W/ 1/4" X 1" 316 SS FLAT BAR. DRILL HOLES 1/2" FROM EACH END AND ONE IN THE CENTER. (A = 3" OR LESS) SPACE OTHER HOLES 3" OR LESS
3. PROVIDE GAS FLAP FOR ALL LATERALS 12" AND LESS, UNLESS OTHERWISE SPECIFIED.

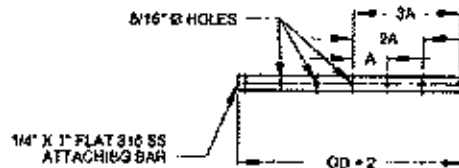

DETAIL 3
ATTACHING BAR SEE NOTE 2

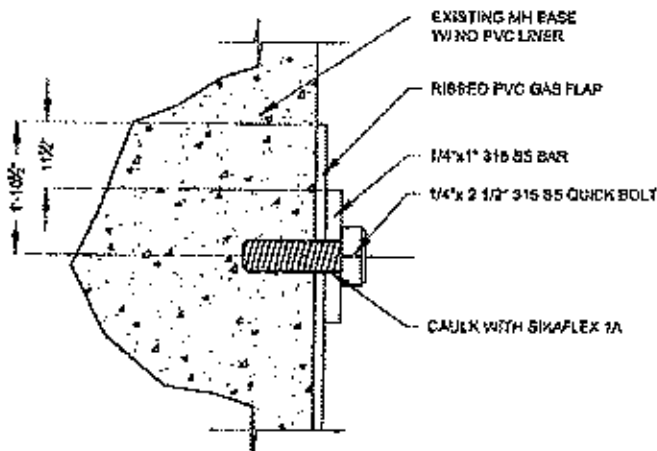

DETAIL 1
NTS

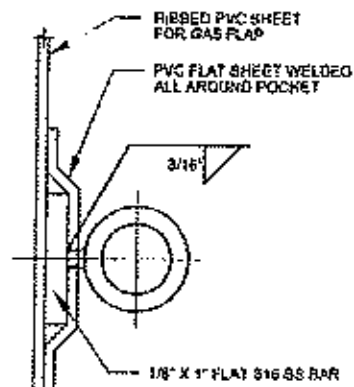

DETAIL 2
NTS

			ANN ARBOR CITY ENGINEERING DISTRICT WESTMINSTER, CALIFORNIA	GAS FLAP INSTALLATION FOR UNPVC LINED OR UNLINED MANHOLES	STANDARD DWG.
NO.	APPROVED	DATE	<i>Henry H. H. 11/20/2010</i>		S-057

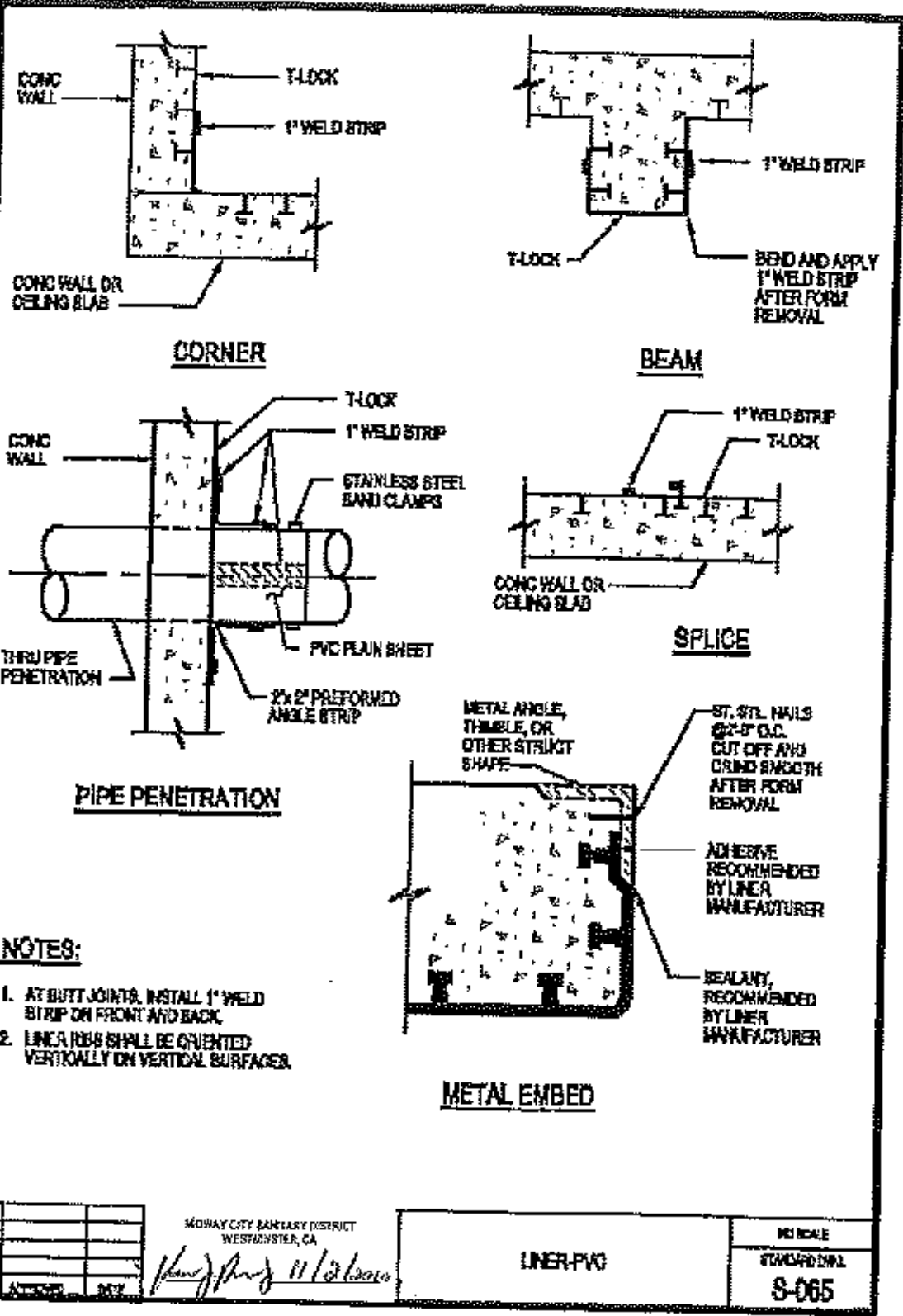

NOTES:

1. AT BUTT JOINTS, INSTALL 1" WELD STRIP ON FRONT AND BACK.
2. LINER JOBS SHALL BE ORIENTED VERTICALLY ON VERTICAL SURFACES.

MOWAY CITY SANITARY DISTRICT
WESTONSTER, GA

Handwritten signature and date: 11/2/2000

LINER-PVC

REVISION
STANDARD DWG.
S-065

THE BELL ON THE COLLAR TEE SADDLE SHALL NOT BE ENCASED IN CONCRETE. TAP SHALL BE MADE AT THE APPROXIMATE CENTERLINE OF THE JOINT. ENCASE 12" EACH SIDE OF OPENING.

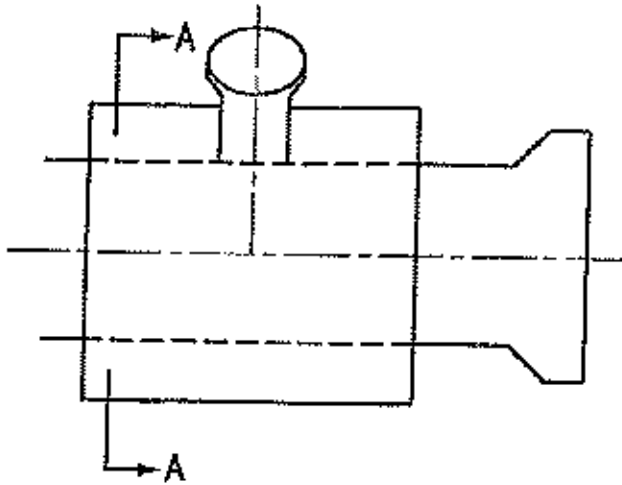

ELEVATION

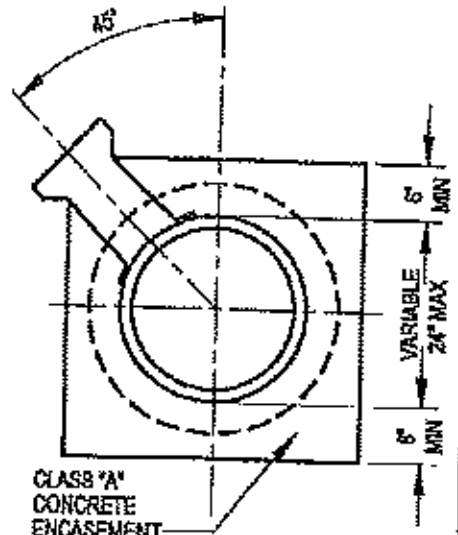

SECTION A-A

NOTE:

SADDLE CONNECTIONS SHALL NOT BE MADE TO SEWERS LARGER THAN 6" I.D.



COLLAR TEE SADDLE

(AS PROVIDED BY MANUFACTURER)

NOTES:

1. THE CONTRACTOR SHALL SECURE THE COLLAR TEE SADDLE TO THE SEWER WITH AN EPOXY RESIN PROVIDED BY THE PIPE MANUFACTURER.
2. THE CONTRACTOR SHALL ENCASE THE SADDLE CONNECTION WITH CLASS 'A' CONCRETE AFTER THE CONNECTION IS INSPECTED BY THE ENGINEER.
3. THE CONTRACTOR SHALL KEEP ALL CLAY CHIPS, DIRT, EPOXY, MORTAR AND CONCRETE OUT OF THE SEWER SADDLE, AND PERFORM A CLEANING AND BALLING OF THE SEWER.
4. THE CONTRACTOR SHALL REPAIR OR REPLACE ANY DAMAGED PIPE AS DIRECTED BY THE ENGINEER.
5. SADDLE CONNECTIONS TO SEWERS 6" IN DIAMETER SHALL BE DONE BY CORE DRILL.

NO.	APPROVED	DATE

MIDWAY CITY SANITARY DISTRICT
WESTMINSTER, CA

Henry Henry 11/2/2010

SADDLE CONNECTION

NO SCALE
STANDARD DWG.
S-070

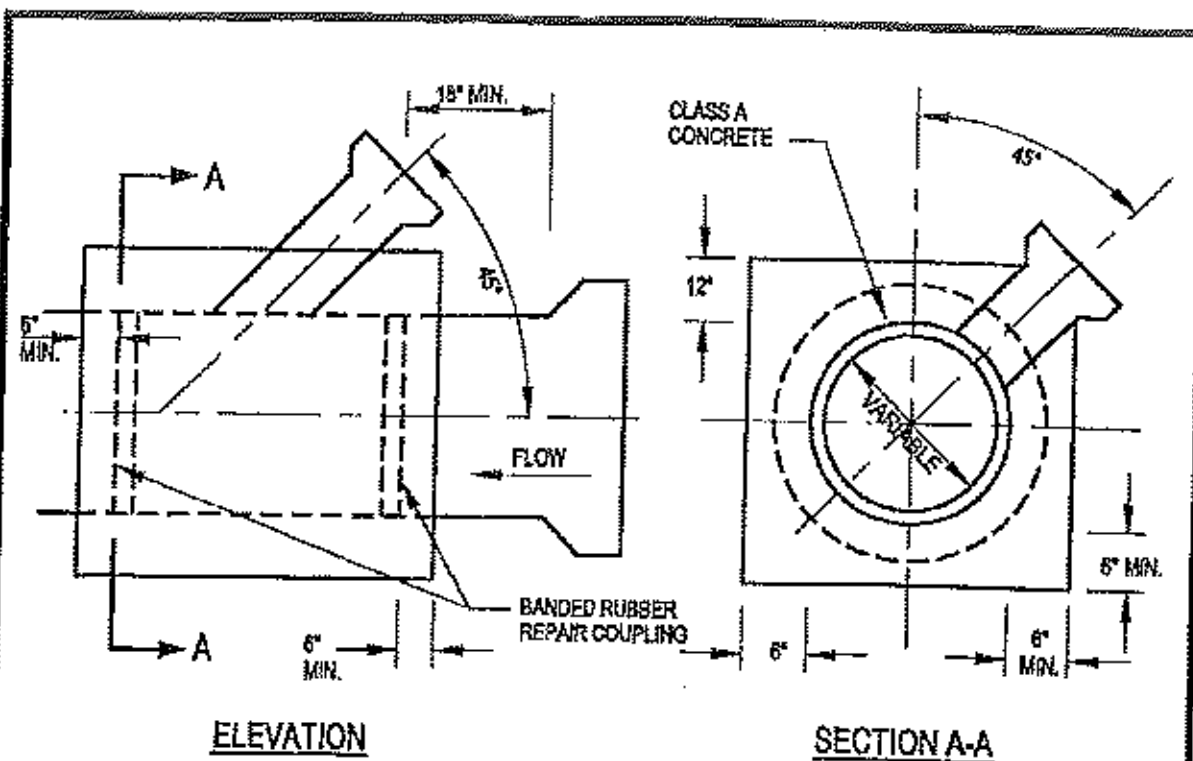

ELEVATION

SECTION A-A

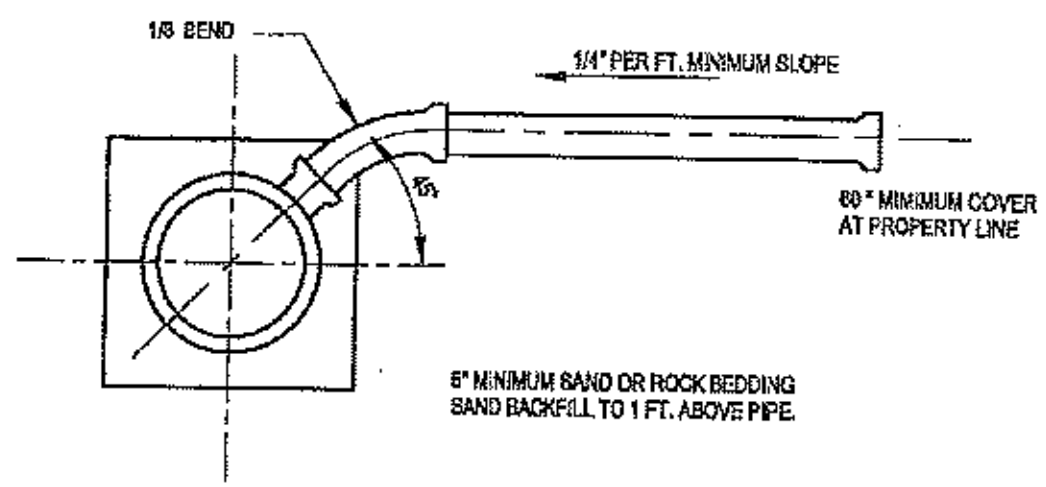

NO.	APPROVED	DATE

MGMAY CITY SANITARY DISTRICT
 WESTMINSTER, CA
11/2/2010

CUT IN WYE CONNECTION

NO SCALE
 STANDARD DWG.
 S-071

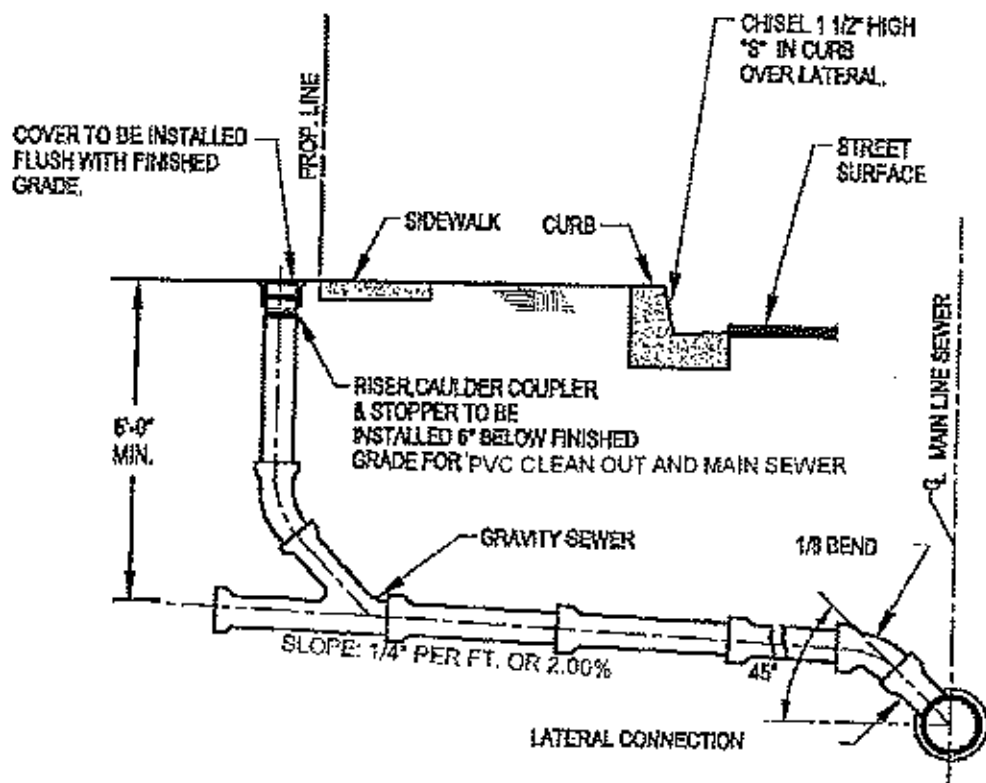

NOTES:

1. FOR SLOPE LESS THAN 1/4" PER FOOT, A 6" CONNECTION SHALL BE USED. MIN. SLOPE = 1/8" PER FT.
2. SEWER CLEANOUT SHALL INCLUDE A STOPPER OVER RISERS.
3. FOR SEWER CLEANOUT RISER USE PIPE OF THE SAME DIAMETER AND MATERIAL USED IN THE ADJOINING SEWER LINE.
4. SINGLE FAMILY RESIDENCES SHALL BE 4" GRAVITY SEWERS, ALL OTHERS SHALL BE 6" OR MORE.
5. A CLEANOUT SHALL BE INSTALLED ON ALL HOUSE CONNECTIONS.
6. GRAVEL OR CRUSHED ROCK BEDDING TO SPRING LINE OF WYE AND 1 FOOT EACH SIDE OF LATERAL.

NO.	APPROVER	DATE

HILWAY CITY SANITARY DISTRICT
WESTMINSTER, CA

[Signature] 11/10/2000

HOUSE LATERAL, TYPICAL

NO SCALE
STANDARD DWG.
S-072

**LAMPHOLE COVER AND FRAME
FOR SEWER LINE INSPECTION AND EXAMINATION**

PLATE NUMBER	CLEAR OPENING	OVERALL BASE	HEIGHT FRAME	APPROX WEIGHT
M-1260	610 10	16	12	

PAINTED: BITUMINOUS PAINT

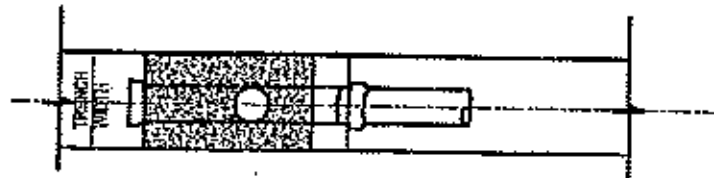
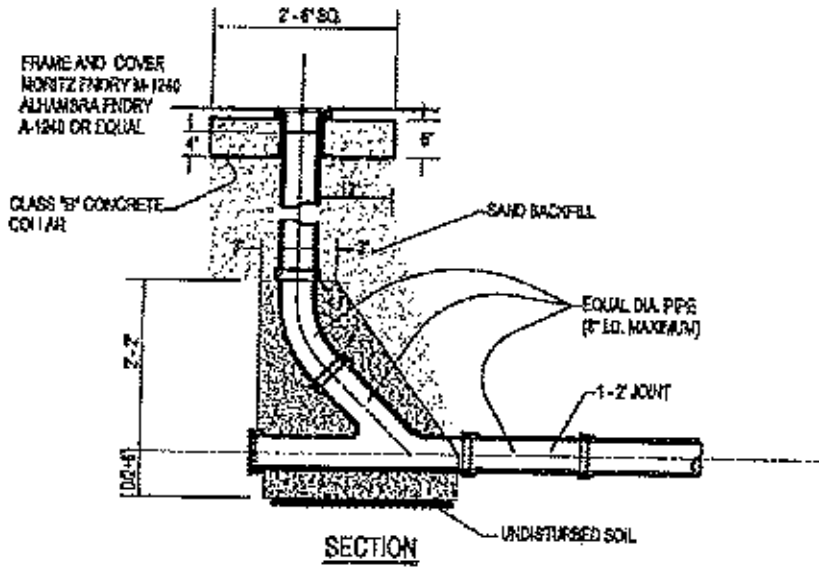
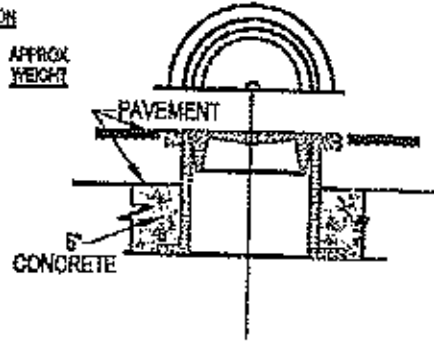

SECTION A-A

NOTES:

- CLEAN OUTS IN PUBLIC RIGHT OF WAY APPROVED FOR USE IN UNINCORPORATED ONLY. PERMISSION TO CONSTRUCT CLEAN OUTS MUST BE OBTAINED FROM THE ENGINEER IN EACH CASE.

NO.	APPROVED	DATE

MIDWAY CITY SANITARY DISTRICT
BESSEMER, CA

Handwritten signature: King King 11/2/2010

**CLEAN OUT
DETAIL
IN ROADWAY**

NO SCALE
STANDARD DWG.
S-073

GREASE INTERCEPTOR TANK WITH SAMPLE BOX

MIDWAY CITY SANITARY DISTRICT
WESTMINSTER, CALIFORNIA

Henry R. Jones 11/12/2010

REQUIREMENTS:

1. Size and location of interceptor to be approved prior to installation.
2. Interceptor to have:
 - a. Sample Box
 - b. Sanitary Tee inside sample box, discharge side
 - c. Vent
 - d. Cleanout prior to lateral connection
 - e. Manhole of each lateral baffle tube - no more than 10' between manholes
3. Inspection of Interceptor
 - a. All connections to interceptor to be inspected prior to backfill.
 - b. Interceptor to be filled with water prior to inspection, per manufacturer's instructions or request.
4. All manholes and sample boxes to be installed a minimum of 1/2" above finish grade/finish with a concrete collar a minimum of 18" around all manhole lids and 12" deep.
5. Concrete Collar, Sample Box fitting and all exterior piping supplied by installer.

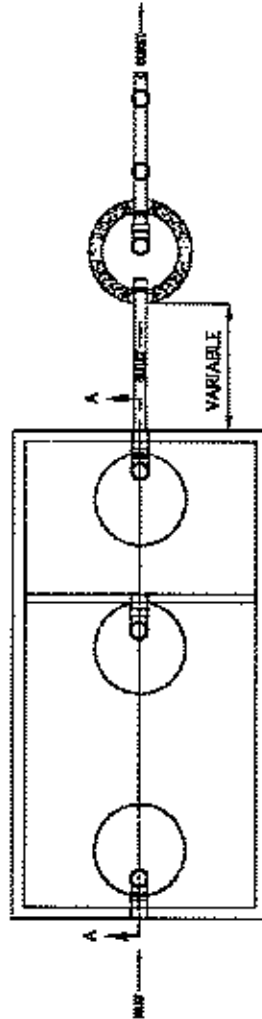

SAMPLE BOX

PLAN VIEW

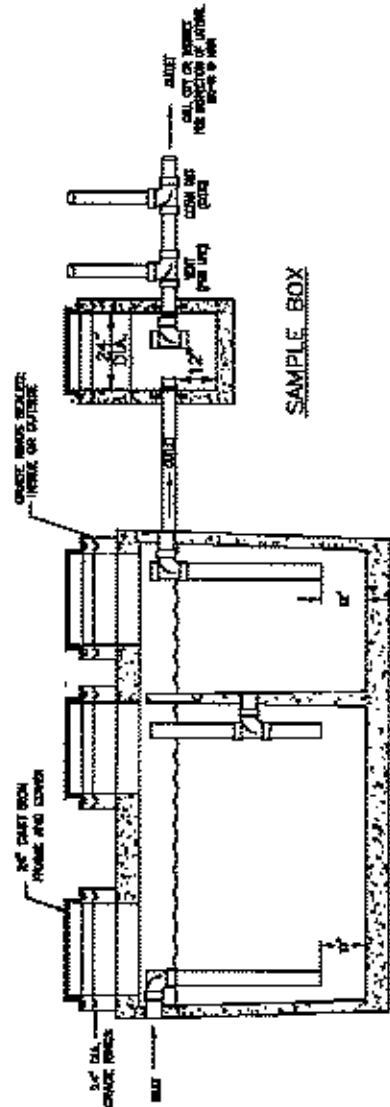

SIDE VIEW

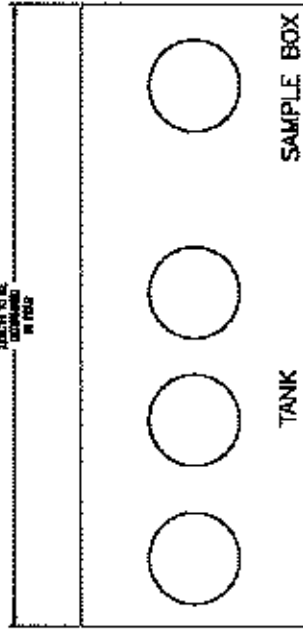

CONCRETE COLLAR DETAIL
PLAN VIEW

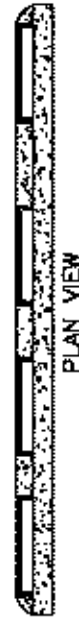

PLAN VIEW



END VIEW

GREASE INTERCEPTOR